

# **BMC 1.5L diesel engine**

## **Workshop Repair Manual**



## INTRODUCTION

This Manual is intended to assist the skilled mechanic in carrying out repairs and replacements in a minimum time. The information at the front of the book includes general data, recommended lubricants, and maintenance. Each major assembly or system is dealt with in a group, each group being sub-divided into parts for easy reference:

- A** Description, Testing, and Adjusting (where applicable).
- B** Removing and Refitting Components.
- C** Overhauling.

An index is provided at the front of each group.

### DISCLAIMER

- (i) Purchasers are advised that the specification details set out in this Manual apply to a range of engines and not to any particular engine. For the specification of any particular engine Purchasers should consult their supplier.
- (ii) The Manufacturers reserve the right to vary their specifications with or without notice, and at such times and in such manner as they think fit. Major as well as minor changes may be involved in accordance with the Manufacturer's policy of constant product improvement.
- (iii) Whilst every effort is made to ensure the accuracy of the particulars contained in this Manual, neither the Manufacturer nor the supplier, by whom this Manual is supplied, shall in any circumstances be held liable for any inaccuracy or the consequences thereof.

### REPAIRS AND REPLACEMENTS

When service parts are required it is essential that only genuine BL or Unipart replacements are used.

Attention is particularly drawn to the following points concerning repairs and the fitting of replacement parts and accessories:

Safety features embodied in the engine may be impaired if other than genuine parts are fitted. In certain territories, legislation prohibits the fitting of parts not to the engine manufacturer's specification. Torque wrench setting figures given in this Manual must be strictly adhered to. Locking devices, where specified, must be fitted. If the efficiency of a locking device is impaired during removal, it must be renewed. When purchasing accessories while travelling abroad ensure that the accessory and its fitted location conform to requirements existing in their country of origin. The engine warranty may be invalidated by the fitting of other than genuine BL or Unipart parts.

All BL or Unipart replacements have the full backing of the factory warranty.

### SERVICE PARTS

**Genuine BL or UNIPART Service Parts are designed and tested for your engine and have the full backing of the BL Cars Warranty. ONLY WHEN GENUINE BL or UNIPART SERVICE PARTS ARE USED CAN RESPONSIBILITY BE CONSIDERED UNDER THE TERMS OF THE WARRANTY.** Genuine parts are supplied in cartons bearing one or both of these symbols:



### COPYRIGHT

© BL Cars Limited 1979.

All rights reserved. No part of this publication may be reproduced, stored in a retrieval system or transmitted, in any form, electronic, mechanical, photocopying, recording or other means without prior written permission of BL Cars, Service, Cowley, Oxford OX4 2PG.



## ABBREVIATIONS

Across flats (bolt head size) .. ..	A.F.	Maximum .. .. .	max.
After bottom dead centre .. ..	A.B.D.C.	Metres .. .. .	m
After top dead centre .. ..	A.T.D.C.	Microfarad .. .. .	mfd
Alternating current .. ..	a.c.	Millimetres .. .. .	mm
Amperes .. .. .	amp	Minimum .. .. .	min.
Ampere-hour .. .. .	Ah	Minus (of tolerance) .. .. .	—
Atmospheres .. .. .	Atm		
		Negative (electrical) .. .. .	—
Before bottom dead centre .. ..	B.B.D.C.		
Before top dead centre .. ..	B.T.D.C.	Ohms .. .. .	ohm or $\Omega$
Bottom dead centre .. ..	B.D.C.	Ounces .. .. .	oz
Brake horse-power .. ..	b.h.p.	Outside diameter .. .. .	o.dia.
British Standards .. ..	B.S.		
		Pints (Imperial) .. .. .	pt
Centigrade (Celsius) .. ..	C	Plus or minus .. .. .	$\pm$
Centimetres .. .. .	cm	Plus (of tolerance) .. .. .	+
Centimetres of mercury .. ..	cmHg	Positive (electrical) .. .. .	+
Cubic centimetres .. .. .	cm <sup>3</sup>	Pounds (force) .. .. .	lbf
Cubic inches .. .. .	in <sup>3</sup>	Pounds (mass) .. .. .	lb
		Pounds feet (torque) .. .. .	lbf ft
Degree, minute, second (angle) .. .. °, ', "		Pounds force per square inch .. ..	lbf/in <sup>2</sup>
Degree (temperature) .. ..	deg. or °	Pounds inches (torque) .. .. .	lbf in
Diameter .. .. .	dia.		
Direct current .. .. .	d.c.	Ratio .. .. .	:
		Revolutions per minute .. .. .	rev/min
Fahrenheit .. .. .	F	Right-hand .. .. .	R.H.
Feet .. .. .	ft	Right-hand drive .. .. .	R.H.D.
Gallons (Imperial) .. .. .	gal	Society of Automobile Engineers .. ..	S.A.E.
Grammes (mass) .. .. .	g	Specific gravity .. .. .	sp. gr.
		Square centimetres .. .. .	cm <sup>2</sup>
Inches .. .. .	in	Square inches .. .. .	in <sup>2</sup>
Inches of mercury .. .. .	inHg	Standard wire gauge .. .. .	s.w.g.
Internal diameter .. .. .	i.dia		
		Top dead centre .. .. .	T.D.C.
Kilogrammes (force) .. .. .	kgf		
Kilogrammes (mass) .. .. .	kg	United Kingdom .. .. .	U.K.
Kilogramme centimetre (force) .. ..	kgf cm		
Kilogramme metres (force) .. ..	kgf m	Volts .. .. .	V
Kilogrammes per square centimetre (force) .. .. .	kgf/cm <sup>2</sup>	Watts .. .. .	W
Kilometres .. .. .	km		
Kilonewtons per square metre .. ..	kN/m <sup>2</sup>	Screw threads:	
		British Association .. .. .	B.A.
Left-hand .. .. .	L.H.	British Standard Fine .. .. .	B.S.F.
Left-hand drive .. .. .	L.H.D.	British Standard Pipe .. .. .	B.S.P.
		Metric (millimetres) .. .. .	M
		Unified Coarse .. .. .	U.N.C.
		Unified Fine .. .. .	U.N.F.

## INDEX

	<i>Group</i>
Cooling System .. .. .	53
Diesel Engine .. .. .	50D
Fuel System .. .. .	51D
General Data .. .. .	Front of Manual
Lubrication .. .. .	Front of Manual
Maintenance .. .. .	Front of Manual
Service Tools .. .. .	End of Manual
Torque Wrench Settings .. .. .	Front of Manual

**NOTE:** The dismantling and assembly procedures in this Manual are presented assuming the engine has been removed from the vehicle.

**MAINTENANCE**

**BLEEDING THE FUEL SYSTEM**

1. Ensure that there is an adequate supply of fuel in the tank.
2. Slacken the union at the filter end of the injection pump feed pipe. Operate the lift pump by hand, and when the fuel coming from the slackened union is free of air bubbles, tighten the union.
3. Slacken the plug in the unused connection in the filter head. Operate the lift pump, and when fuel coming from the connection is free of air bubbles, tighten the plug.
4. Slacken the two bleed valves on the injection pump illustrated in Fig. 1. Operate the lift pump, and when fuel coming from both valves is free of air bubbles, tighten the valves.
5. Slacken the unions at the injector ends of any two high-pressure pipes. Ensure that the stop control is in the run position and the throttle in the fully open position. Crank the engine until the fuel coming from both pipes is free of air bubbles, then tighten the unions.
6. Start the engine and allow it to run until it is running on all four cylinders.

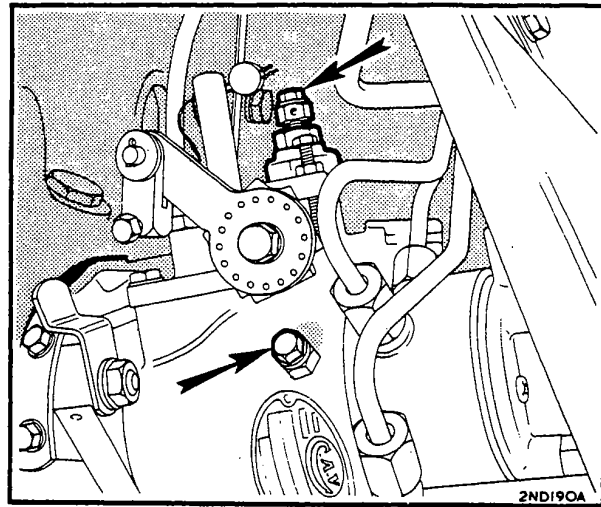
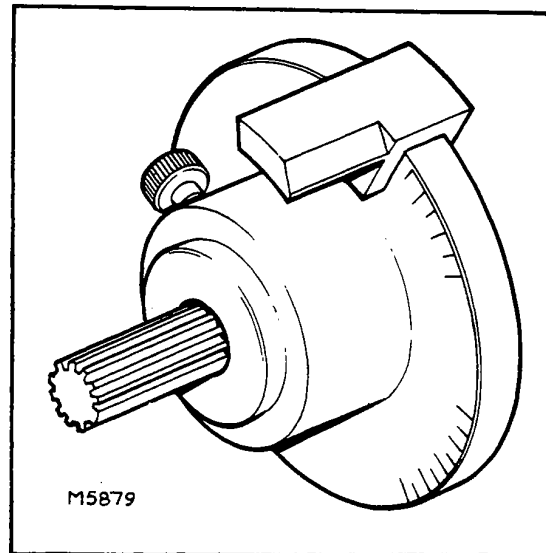

Fig. 1

**WARNING:** As the injection pump is lubricated by fuel under pressure, no attempt should be made to bleed the system by towing a vehicle in gear.

**INJECTION TIMING ADJUSTMENT**

1. Set No. 1 piston at 22° B.T.D.C. on compression stroke.
2. Set the scriber arm MS67A/2B to 208° on the universal timing gauge MS67A and lock in position.
3. Engage the timing gauge splined shaft with the injection pump drive and slide the gauge body up to the mounting face. Lock the body to the shaft with the nylon screw.
4. Eliminate backlash by light clockwise pressure on the gauge.
5. Set the pointer, if necessary, to align with the scribing edge.
6. Remove the timing gauge.
7. Position the injection pump so that the mark on its mounting flange is aligned with the timing pointer.



## MAINTENANCE

---

### VALVE ROCKER CLEARANCE ADJUSTMENT

The correct clearance between the valve rockers and the valve stem is given in 'GENERAL DATA'. Remove the rocker cover and check the clearance between the rocker and the valve stem in the order shown below.

Adjust No. 1 rocker with No. 8 valve fully open

"	"	3	"	"	"	6	"	"	"
"	"	5	"	"	"	4	"	"	"
"	"	2	"	"	"	7	"	"	"
"	"	8	"	"	"	1	"	"	"
"	"	6	"	"	"	3	"	"	"
"	"	4	"	"	"	5	"	"	"
"	"	7	"	"	"	2	"	"	"

Adjust if necessary, by slackening the locking nut and turning the adjusting screw in the appropriate direction until the clearance is correct. Hold the screw against rotation and tighten the locking nut. Refit the rocker cover and check that its gasket is serviceable.

---

### GOVERNED SPEED ADJUSTMENT

With the engine at normal running temperature make the following settings:

1. Set the maximum speed stop screw to give 4400 rev/min.
2. Set the idling stop screw to give 500 to 600 rev/min.
3. Open the throttle a little to give a slight increase in rev/min.
4. Unscrew the idling damper adjusting screw one-third of a turn.
5. Run the engine at three-quarter of maximum rev/min. and release the throttle.
  - a. If the engine stalls, screw the damper adjusting screw in slightly.
  - b. If engine die-down is sluggish, screw the damper adjusting screw out slightly.
6. Check the operation of the stop control.





**GENERAL DATA**

## GENERAL DATA

---

### ENGINE

Engine type .. .. .	15V
Number of cylinders .. .. .	4
Bore .. .. .	73.01 to 73.05 mm (2.8745 to 2.876 in)
Stroke .. .. .	88.9 mm (3.5 in)
Capacity .. .. .	1489 cm <sup>3</sup> (90.88 in <sup>3</sup> )
Compression ratio .. .. .	23 : 1
Firing order .. .. .	1, 3, 4, 2
Idling speed .. .. .	500 to 600 rev/min
Maximum governed speed .. .. .	4,400 rev/min
Oil pressure:	
Idling .. .. .	1.05 kgf/m <sup>2</sup> (15 lbf/in <sup>2</sup> )
Normal running .. .. .	3.52 kgf/m <sup>2</sup> (50 lbf/in <sup>2</sup> )
Valve rocker clearance (cold) .. .. .	0.38 mm (0.015 in)

---

### FUEL SYSTEM

Injection pump .. .. .	C.A.V. DPA. 3246F857
Injectors .. .. .	C.A.V.
Nozzle .. .. .	BDN.0.SCP.5389
Nozzle holder .. .. .	BKB.35.SD.5188
Nozzle opening pressure .. .. .	135 atmospheres
Lift pump .. .. .	A.C. mechanical, U-type
Main filter .. .. .	C.A.V. FS.5836020
Lift pump static pressure (no delivery) .. .. .	0.35 to 0.56 kgf/cm <sup>2</sup> (5 to 8 lbf/in <sup>2</sup> )

---

### CAPACITIES

Engine oil (including filter) .. .. .	4.7 litres (8.25 imp. pints)
---------------------------------------	------------------------------

---

**TORQUE WRENCH SETTINGS**

## TORQUE WRENCH SETTINGS

### ENGINE

Big-end bolts .. .. .	4.84 kgf m (35 lbf ft)
Cylinder head nuts .. .. .	9.8 kgf m (71 lbf ft)
Flywheel bolts .. .. .	5.1 kgf m (37 lbf ft)
Fuel injector securing nuts .. .. .	1.7 kgf m (12 lbf ft)
Main bearing nuts .. .. .	10.4 kgf m (75 lbf ft)
Manifold nuts .. .. .	2.1 kgf m (15 lbf ft)
Rear distance piece bolts: $\frac{5}{16}$ in .. .. .	2.8 kgf m (20 lbf ft)
$\frac{3}{8}$ in .. .. .	4.1 kgf m (30 lbf ft)
Rocker bracket nuts .. .. .	3.4 kgf m (25 lbf ft)
Water pump bolts .. .. .	2.3 kgf m (17 lbf ft)

### INJECTION PUMP

Advance unit cap nut .. .. .	1.5 kgf m (130 lbf in)
Advance unit cap nut stud .. .. .	0.69 kgf m (60 lbf in)
Advance unit spring cap and end-plug .. .. .	2.88 kgf m (250 lbf in)
Cam ring advance screw .. .. .	5.02 kgf m (450 lbf in)
Drive plate screws:	
Direct torque .. .. .	1.85 kgf m (160 lbf in)
Indirect torque (using tool 18G 655 A) .. .. .	1.62 kgf m (140 lbf in)
End plate studs .. .. .	0.52 kgf m (45 lbf in)
Fuel inlet connection .. .. .	5.02 kgf m (450 lbf in)
Governor housing securing screws .. .. .	0.46 kgf m (40 lbf in)
High-pressure connections .. .. .	3.12 kgf m (270 lbf in)
Hydraulic head locating bolt .. .. .	4.03 kgf m (350 lbf in)
Hydraulic head locating screws .. .. .	1.96 kgf m (170 lbf in)
Rotor end-plug .. .. .	0.52 kgf m (28 lbf in)
Transfer pump rotor .. .. .	0.75 kgf m (65 lbf in)

### INJECTORS

Nozzle nut .. .. .	6.91 kgf m (50 lbf ft)
--------------------	------------------------

# LUBRICATION

RECOMMENDED LUBRICANTS

Component	Engine and Oil-can Points				Grease Points
	Temperatures above 20°C (68°F)*	Temperatures -10°C (15°F) to 30°C (85°F)*	Temperatures -20°C (-5°F) to 0°C (32°F)*	Temperatures below -15°C (5°F)†	All conditions
Minimum performance level	MIL-L-46152 or MIL-L-2104B	MIL-L-46152 or MIL-L-2104B	MIL-L-46152 or MIL-L-2104B	MIL-L-46152 or MIL-L-2104B	Multipurpose Lithium Grease N.L.G.1 Consistency No. 2
<b>CASTROL</b>	Castrol-Deusol CRB 30, 20W/50 or Deusol RX Super 20W/40	Castrol-Deusol CRB 20, 20W/50 or Deusol RX Super 20W/40	Castrol-Deusol CRB 10 or Castrol Deusol CRB 10W/30	Castrol GTZ	Castrol L.M. Grease
<b>ESSO</b>	Essolube HDX 30	Essolube HDX 20	Essolube HDX 10W	Esso Extra Motor Oil 5W/20	Esso Multipurpose Grease H
<b>MOBIL</b>	Delvac 1230	Delvac 1220	Delvac 1210	Mobiloil 5W/20	Mobilgrease MP
<b>BP</b>	Vanellus S.A.E. 30	Vanellus S.A.E. 20W	Vanellus S.A.E. 10W	Super Visco-Static 5W/20	BP Energrease L 2
<b>SHELL</b>	Shell Rotella T Oil 30	Shell Rotella T Oil 20/20W	Shell Rotella T Oil 10W	Shell Super Motor Oil 5W/30	Shell Retinax A
<b>TEXACO</b>	Ursatex S.A.E. 30 or S.A.E. 20W/50	Ursatex S.A.E. 20/20W or S.A.E. 20W/50	Ursatex S.A.E. 10W or S.A.E. 10W/30	Havoline S.A.E. 5W/30	Marfak All-purpose
<b>PETROFINA</b>	Fina Delta Plus S.A.E. 30 S.A.E. 20W/50 or Delta HPD	Fina Delta Plus S.A.E. 20W/20 S.A.E. 20W/50 or Delta HPD	Fina Delta S.A.E. 10W or S.A.E. 10W/30	Fina Supergrade 5W/50	Fina HTL 2
<b>DUCKHAMS</b>	Fleetol HDX 30	Fleetol HDX 20	Fleetol HDX 10	Duckhams Q 5-30	Duckhams LB 10 Grease

\* The appropriate multigrade oil, supplied by approved companies, is approved for the particular conditions prevailing.  
 † Or the current practice of the country concerned.

## 1.5 LITRE DIESEL ENGINE

<b>A DESCRIPTION</b>	<i>Page</i>	<i>Section</i>
External components .. .. .	A4	
Internal components .. .. .	A6	
Key to external components .. .. .	A5	
Key to internal components .. .. .	A7	
Longitudinal section .. .. .	A3	
Transverse section .. .. .	A2	
<b>B REMOVING AND REFITTING COMPONENTS</b>		
Camshaft and front plate .. .. .	B6 .. ..	B8
Connecting rods and pistons .. .. .	B8 .. ..	B9
Crankshaft .. .. .	B9 .. ..	B11
Cylinder head .. .. .	B3 .. ..	B3
Engine (with gearbox) .. .. .	B2 .. ..	B1
Flywheel .. .. .	B9 .. ..	B10
Fuel injection pump driving spindle .. .. .	B5 .. ..	B6
Oil pump and driving spindle .. .. .	B5 .. ..	B7
Timing chain, chain wheels and chain tensioner .. .. .	B4 .. ..	B5
Timing chain tensioner .. .. .	B4 .. ..	B4
Valve rocker shaft and tappets .. .. .	B3 .. ..	B2
<b>C OVERHAULING</b>		
Camshaft bearing liners .. .. .	C5 .. ..	C7
Connecting rod and piston .. .. .	C8 .. ..	C10
Cylinder bores .. .. .	C7 .. ..	C9
Cylinder head .. .. .	C3 .. ..	C2
Flywheel .. .. .	C7 .. ..	C8
Injection pump driving gear lubricator and filter .. .. .	C4 .. ..	C5
Oil pressure relief valve .. .. .	C4 .. ..	C4
Oil pump .. .. .	C5 .. ..	C6
Timing chain tensioner .. .. .	C3 .. ..	C3
Valve rocker shaft and tappets .. .. .	C2 .. ..	C1





**A**  
**DESCRIPTION**

TRANSVERSE SECTION

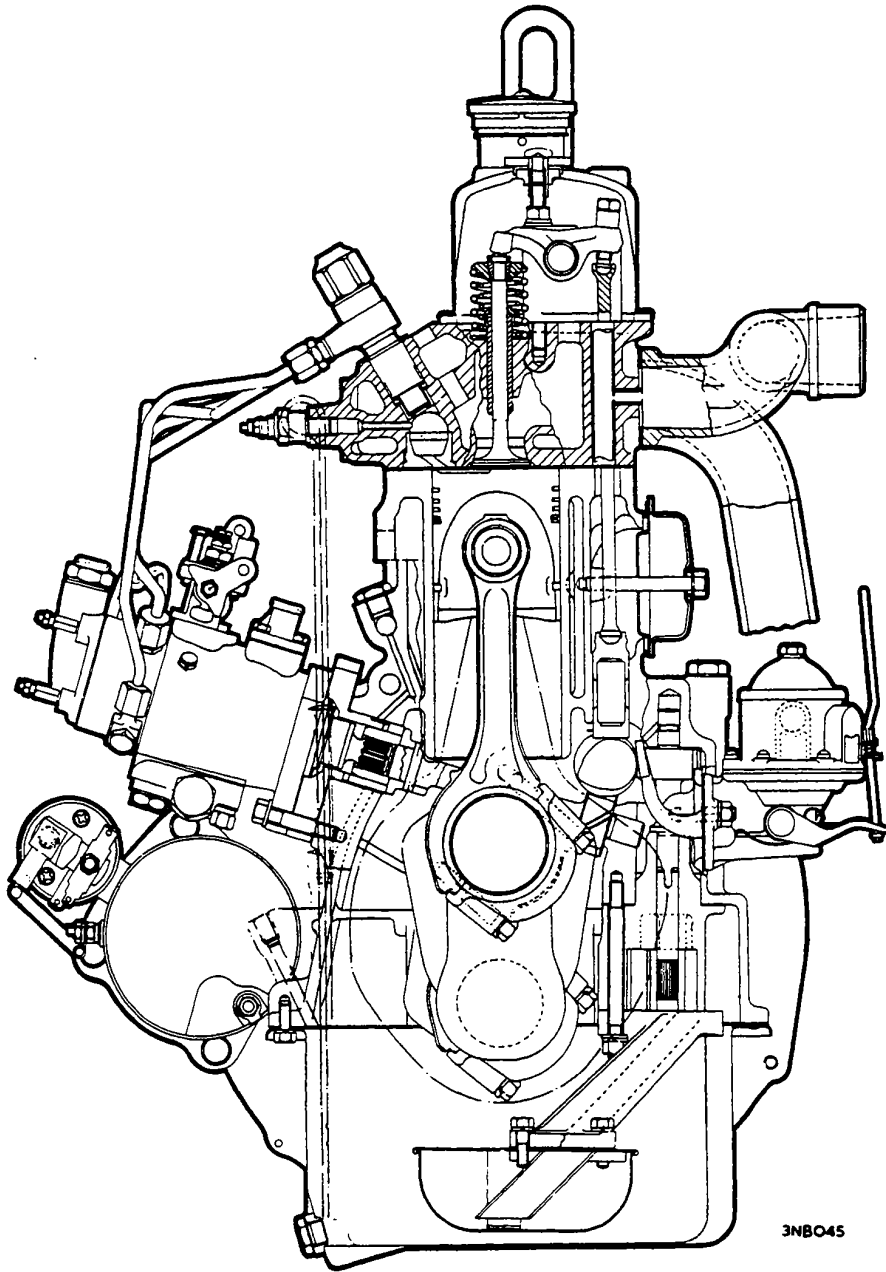

3NBO45

LONGITUDINAL SECTION

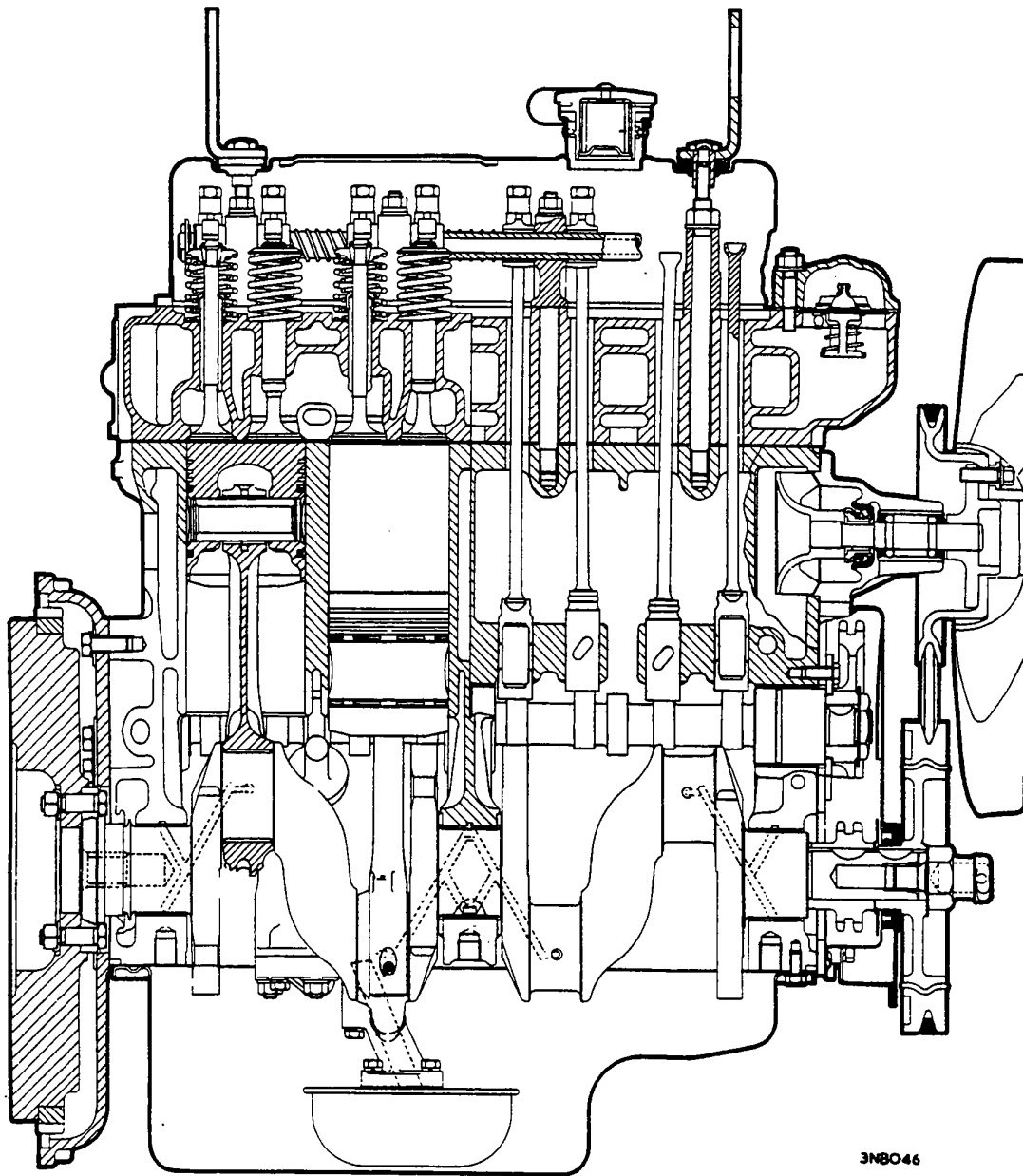

3N8046

EXTERNAL COMPONENTS

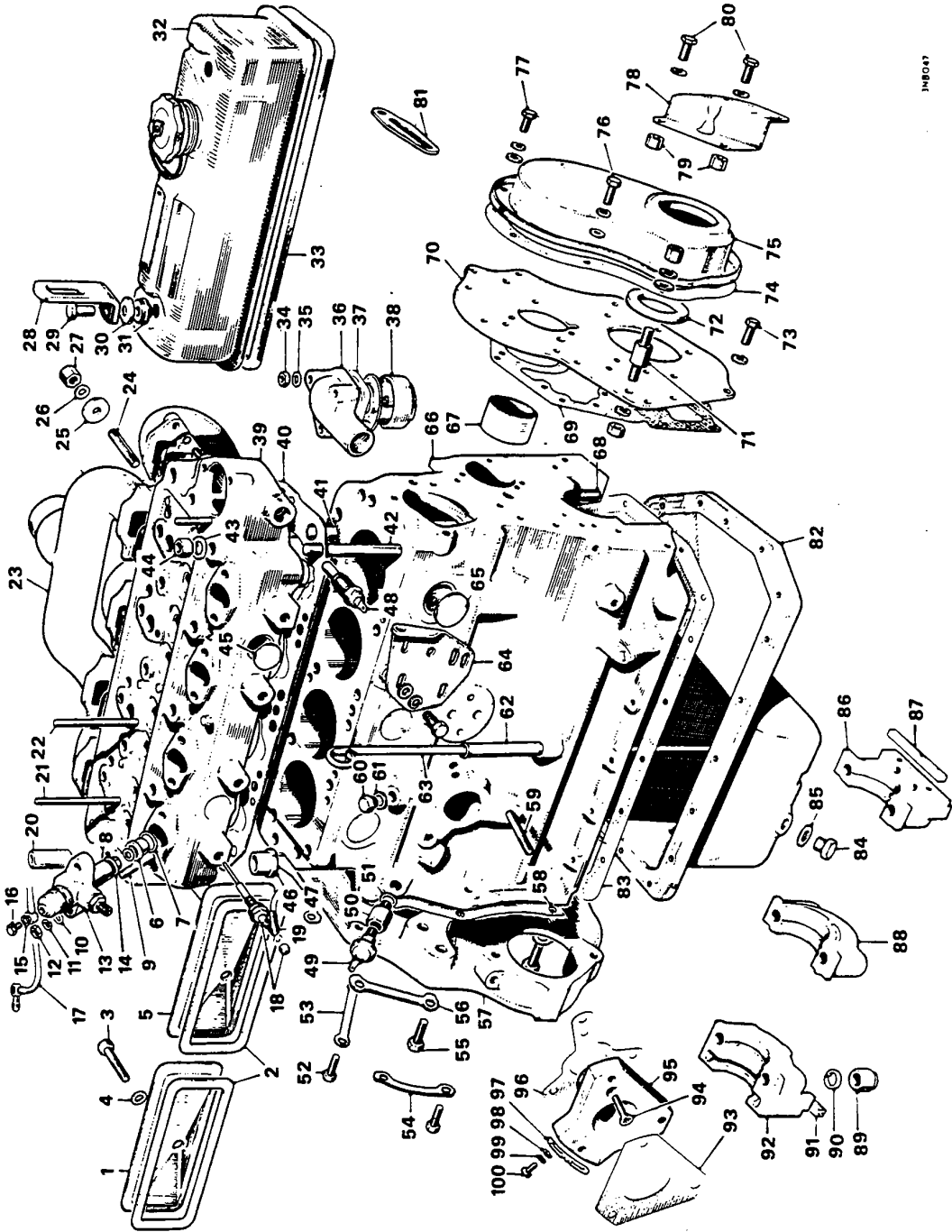

JNB047

KEY TO EXTERNAL COMPONENTS

No.	Description	No.	Description	No.	Description
1.	Tappet side cover—rear	35.	Washer for nut	68.	Stud for main bearing cap
2.	Gasket for side cover	36.	Water outlet elbow	69.	Gasket for engine front plate
3.	Bolt for side cover	37.	Gasket for elbow	70.	Engine front plate
4.	Washer for bolt	38.	Thermostat	71.	Pillar for alternator adjusting link
5.	Tappet side cover—front	39.	Cylinder head	72.	Crankshaft oil seal
6.	Heat shield	40.	Gasket for cylinder head	73.	Screw for front plate
7.	Joint washer for heat shield	41.	Cylinder head stud (long)	74.	Gasket for front cover
8.	Atomizer seal washer	42.	Cylinder head stud (short)	75.	Front cover
9.	Stud for injector	43.	Washer for stud	76.	Screw for front cover and front plate
10.	Washer for nut	44.	Nut for stud	77.	Screw for front cover
11.	Spring washer for nut	45.	Core plug	78.	Timing plate
12.	Nut for injector stud	46.	Combustion chamber insert	79.	Distance piece
13.	Injector	47.	Ball for insert (if fitted)	80.	Screw for timing plate
14.	Joint washer for injector	48.	Thermal transmitter	81.	Adjusting link for alternator
15.	Washer for banjo bolt	49.	Oil pressure switch	82.	Oil sump
16.	Banjo bolt	50.	Adaptor for switch	83.	Gasket for sump
17.	Leak-off pipe	51.	Seal washer for adaptor	84.	Drain plug for sump
18.	Heater plug	52.	Screw for gearbox distance piece	85.	Washer for drain plug
19.	Cable for heater plug	53.	Lock washer for screw	86.	Front main bearing cap
20.	Pedestal for fuel filter bracket	54.	Lock washer for screw	87.	Joint for main bearing cap
21.	Long stud for rocker bracket	55.	Screw for gearbox distance piece	88.	Centre main bearing cap
22.	Short stud for rocker bracket	56.	Lock washer for screw	89.	Nut for main bearing cap
23.	Inlet manifold	57.	Gearbox distance piece	90.	Washer for nut
24.	Stud for manifold	58.	Gasket for distance piece	91.	Joint for rear main bearing cap
25.	Large washer for stud	59.	Stud for injector pump	92.	Rear main bearing cap
26.	Washer for stud	60.	Plug for oil gallery	93.	Gasket for injection pump
27.	Nut for stud	61.	Washer for plug	94.	Countersunk screw for hub
28.	Engine sling bracket	62.	Guide tube for dipstick	95.	Hub for injection pump
29.	Cap nut for rocker cover	63.	Oil dipstick	96.	Gasket for hub
30.	Cup washer	64.	Bracket for alternator	97.	Timing pointer
31.	Rubber bush	65.	Core plug	98.	Plain washer
32.	Rocker cover	66.	Cylinder block	99.	Spring washer
33.	Gasket for rocker cover	67.	Camshaft bearing liner	100.	Screw for timing pointer
34.	Nut for water outlet elbow				

INTERNAL COMPONENTS

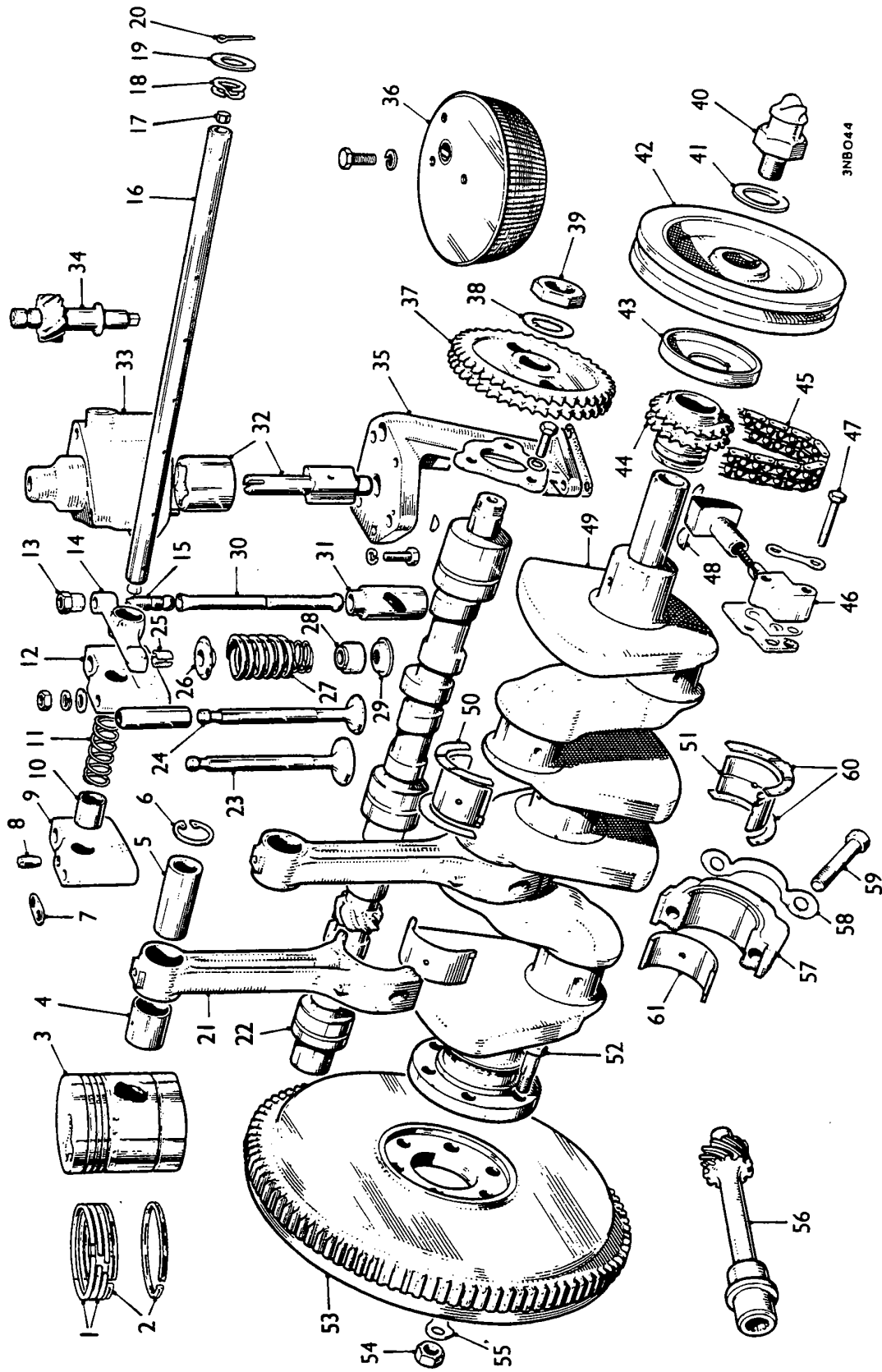

3NBO44

KEY TO INTERNAL COMPONENTS

No.	Description	No.	Description	No.	Description
1.	Piston rings—compression	22.	Camshaft	42.	Crankshaft pulley
2.	Piston rings—oil scraper	23.	Inlet valve	43.	Crankshaft oil thrower
3.	Piston	24.	Exhaust valve	44.	Crankshaft chain wheel
4.	Small end bush	25.	Valve cotters	45.	Timing chain
5.	Gudgeon pin	26.	Valve spring cap	46.	Chain tensioner
6.	Circlip for gudgeon pin	27.	Valve springs	47.	Bolt for chain tensioner
7.	Locking plate for locating screw	28.	Valve stem oil seal	48.	Key for crankshaft
8.	Rocker shaft locating screw	29.	Valve spring bottom collar	49.	Crankshaft
9.	Rocker bracket (tapped)	30.	Push-rod	50.	Crankshaft thrust washer (upper)
10.	Bush for rocker	31.	Tappet	51.	Main bearing shell
11.	Spacing spring for rocker	32.	Oil pump rotor assembly	52.	Flywheel bolt
12.	Rocker bracket (plain)	33.	Oil pump body	53.	Flywheel
13.	Locknut for adjusting screw	34.	Oil pump driving spindle	54.	Nut for flywheel bolt
14.	Valve rocker	35.	Oil pump cover	55.	Lock washer for nut
15.	Adjusting screw for rocker	36.	Oil strainer	56.	Injection pump driving spindle
16.	Rocker shaft	37.	Camshaft chain wheel	57.	Connecting rod cap
17.	Plug for rocker shaft	38.	Lock washer for nut	58.	Lock washer for bolt
18.	Double-coil spring washer	39.	Camshaft nut	59.	Bolt for connecting rod cap
19.	Rocker shaft washer	40.	Starting nut	60.	Crankshaft thrust washer (lower)
20.	Split pin	41.	Lock washer for nut	61.	Big-end bearing shell
21.	Connecting rod				





**B**

**REMOVING AND REFITTING  
COMPONENTS**

## Section B1

## ENGINE (with gearbox)

**Removing**

1. Drain the cooling system.
2. Disconnect the battery.
3. Remove engine cover.
4. Remove the radiator.
5. Remove the breather pipe from the air cleaner.
6. Slacken the clip retaining the air cleaner assembly to the inlet manifold and detach the air cleaner assembly.
7. Disconnect the exhaust pipe from the exhaust manifold.
8. Disconnect the fuel feed pipe from the fuel lift pump.
9. Disconnect the electrical leads from the thermal transmitter, oil pressure switch, heater plugs, alternator and starter.
10. Disconnect the throttle and stop control cable from the fuel injection pump. See Fig. 1.
11. Remove the nuts securing the cable abutment bracket to the fuel injection pump and detach the bracket and cables from the pump (Fig. 1).
12. Disconnect the fuel leak-off pipe from its union on the top of the fuel filter.
13. Support the engine with an overhead crane or hoist, with the point of lift towards the rear of the engine.
14. Disconnect the engine earth cable from the body.
15. Disconnect the exhaust pipe front clip from its bracket.
16. Remove the bolts securing engine mounting.
17. Remove the screws and bolts securing the flywheel housing.
18. Lift the engine clear of the frame.

**Refitting**

19. Reverse the procedure in 1 to 18, noting:
  - a. Bleed the fuel system.

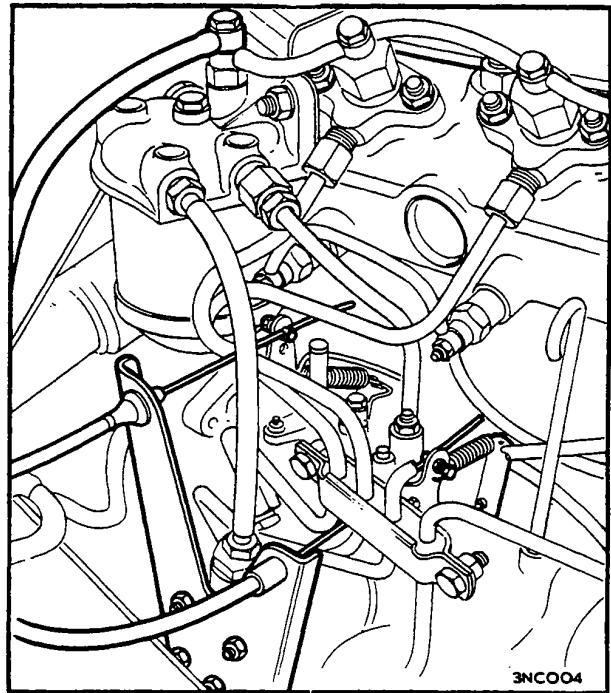

Fig. 1

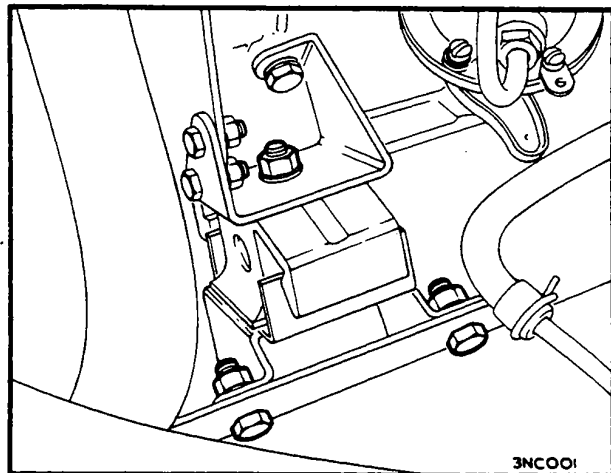

Fig. 2

Section B2

VALVE ROCKER SHAFT AND TAPPETS

Removing

1. Disconnect the battery and drain the cooling system.
2. Remove the air cleaner.
3. Remove the valve rocker cover.
4. Slacken the cylinder head nuts in the order shown in Fig. 1, using tool 18G 694.
5. Release the rocker brackets from the cylinder head and lift off the rocker shaft assembly.
6. Withdraw the push-rods, storing them in the correct order for replacement.
7. Remove the cylinder side covers.
8. Lift out the tappets, storing them in the correct order for replacement.

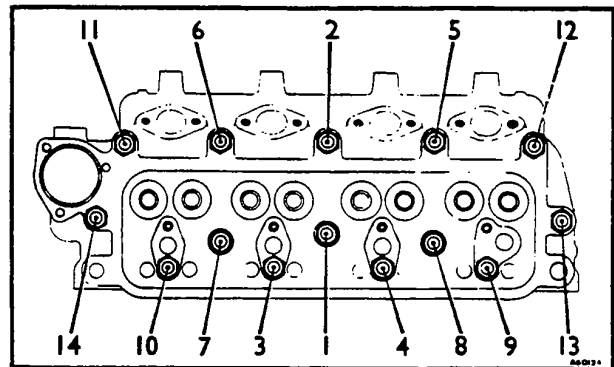

Fig. 1

Refitting

9. Reverse the procedure in 1 to 8, noting:
  - a. Refer to Data for torque wrench settings.
  - b. Tighten the cylinder head nuts in the order shown in Fig. 1.
  - c. Adjust the valve rocker clearances.

Data

Torque wrench setting for cylinder head nuts . . . . . 918 kgf m (71 lbf ft)

Section B3

CYLINDER HEAD

Removing

1. Disconnect the battery and drain the cooling system.
2. Remove the air cleaner.
3. Remove the valve rocker cover and rocker shaft.
4. Withdraw the push-rods.
5. Release the leak-off pipe from its union on the fuel filter head.
6. Remove the high-pressure fuel feed pipes and the injection pump feed and return pipes.
7. Remove the main fuel filter and its mounting bracket.

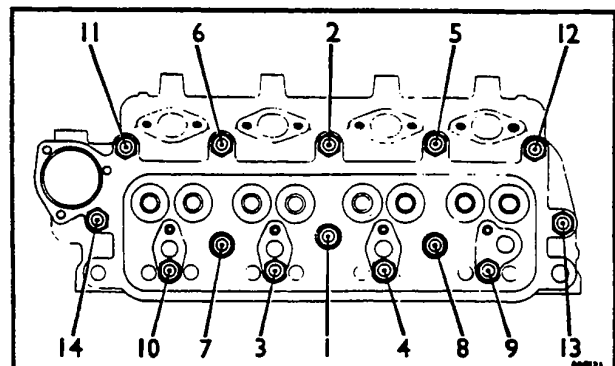

Fig. 1

8. Disconnect the electrical lead from the heater plugs and the thermal transmitter.
9. Remove the clamp and release the exhaust pipe from the exhaust manifold.
10. Remove the exhaust and inlet manifold from the cylinder head.
11. Disconnect the top water hose.
12. Remove the cylinder head nuts and lift off the cylinder head.

**NOTE:** Should combustion chamber inserts drop when the cylinder head is lifted they must be

refitted in their original positions because the cylinder head face is machined with the inserts installed.

#### Refitting

13. Reverse the procedure in 1 to 12, noting:
  - a. Refer to Data for torque wrench settings.
  - b. Tighten the cylinder head nuts in the order shown in Fig. 1, using tool 18G 694.
  - c. Adjust the valve rocker clearances.
  - d. Bleed the fuel system.

#### Data

Torque wrench setting for cylinder head nuts . . . . . 9.8 kgf m (71 lbf ft)

### Section B4

#### TIMING CHAIN TENSIONER

##### Removing

1. Disconnect the battery and drain the cooling system.
2. Remove the radiator.
3. Slacken the alternator mounting bolts and remove the driving belt.
4. Remove the fan blades and pulley.
5. Remove the crankshaft nut, using tool 18G 98 A, and withdraw the crankshaft pulley.
6. Remove the timing chain cover.
7. Unlock and remove the chain tensioner securing screws.
8. Carefully prise the tensioner assembly out of its register in the front engine plate. The slipper head is under spring tension.
9. Allow the spring loading against the slipper head to relax and withdraw the slipper head, spring and inner cylinder from the tensioner body.

##### Refitting

10. Refit the inner cylinder and spring into the cylinder of the slipper head so that the serrated helical slot in the inner cylinder engages with the peg in the slipper cylinder.
11. Turn the inner cylinder clockwise against spring tension until the lower serration in the slot engages with the peg and retains the inner cylinder in the slipper cylinder.
12. Refit the assembly in the tensioner body and fit to the engine.
13. Press the slipper head into the body against the spring and release it smartly to disengage the inner cylinder and allow the spring to re-assert itself fully against the slipper head and timing chain.

#### Data

Maximum permissible body bore ovality . . . . . 0.076 mm (0.003 in)

### Section B5

#### TIMING CHAIN, CHAIN WHEELS AND CHAIN TENSIONER

##### Removing

1. Disconnect the battery and drain the cooling system.
2. Remove the radiator.
3. Slacken the alternator mounting bolts and remove the driving belt.

4. Remove the fan blades and pulley.
5. Remove the crankshaft nut, using tool 18G 98 A, and withdraw the crankshaft pulley.
6. Remove the timing gear cover.
7. Remove the oil thrower from the crankshaft.

8. Unlock and remove the camshaft nut, using tool 18G 98 A.
9. Position the chain wheel timing marks as shown in Fig. 1.
10. Remove the chain tensioner.
11. Draw the two chain wheels off their shafts complete with chain.

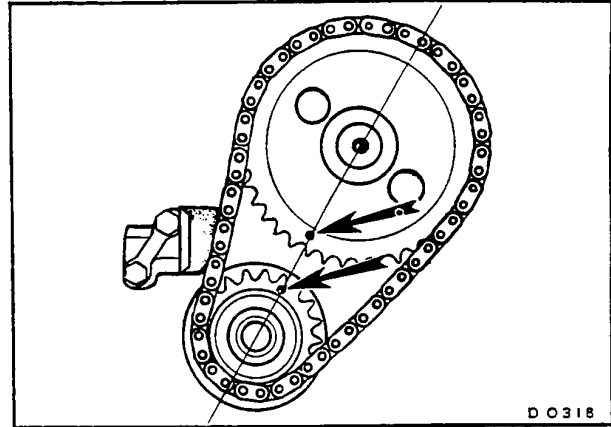

Fig. 1

**Refitting**

12. Reverse the procedure in 1 to 11, noting:
  - a. Check the chain wheel alignment (see Data).
  - b. Assemble the chain wheels and chain on the shafts with the timing marks as shown in Fig. 1.
  - c. Ensure the crankshaft front oil seal in the cover is serviceable. Renew the seal if necessary, using tools 18G 134 and 18G 134 BD.
  - d. Centralize the timing gear cover with the crankshaft using tool 18G 1046.

**Data**

Crankshaft chain wheel face aligned rearwards of camshaft

chain wheel face by	..	..	..	..	..	0-127 mm (0-005 in)
Method of adjustment	..	..	..	..	..	Shims behind crankshaft chain wheel

**Section B6**

**FUEL INJECTION PUMP DRIVING SPINDLE**

**Removing**

1. Disconnect the battery.
2. Remove the fuel injection pump.
3. Remove the countersunk screw and withdraw the fuel injection pump hub from the crankcase.
4. Withdraw the injection pump driving spindle, rotating it clockwise to disengage it from the camshaft gear.

**Refitting**

5. Reverse the procedure in 1 to 4, noting:
  - a. Ensure that, when the driving spindle is fully home, its master spline is in the 5 o'clock position with No. 1 piston at 22° B.T.D.C. on compression stroke.
  - b. When refitting the fuel injection pump, position it as described in 'MAINTENANCE'.
  - c. Bleed the fuel system (see 'MAINTENANCE').
  - d. Adjust the governed speed (see 'MAINTENANCE').

**Section B7**

**OIL PUMP AND DRIVING SPINDLE**

**Removing**

1. Disconnect the battery and drain the oil from the sump.
2. Remove the starter motor.
3. Remove the sump.
4. Disconnect the oil suction pipe from the oil pump.

5. Remove the oil strainer assembly.
6. Remove the securing nuts and withdraw the oil pump.
7. Remove the fuel injection pump.
8. Remove the countersunk screw and withdraw the fuel injection pump hub from the crankcase.

9. Withdraw the fuel injection pump drive spindle.
10. Withdraw the oil pump driving spindle.

#### Refitting

11. Reverse the procedure in 1 to 10, noting:
  - a. Ensure that, when the injection pump driving spindle is fully home, its master spline is in the 5 o'clock position with No. 1 piston at 22° B.T.D.C. on compression stroke.
  - b. When refitting the fuel injection pump, position it as described in 'MAINTENANCE'.
  - c. Bleed the fuel system (see 'MAINTENANCE').
  - d. Adjust the governed speed (see 'MAINTENANCE').

### Section B8

#### CAMSHAFT AND FRONT PLATE

##### Removing

1. Disconnect the battery and drain the cooling system.
2. Remove the radiator.
3. Slacken the alternator mounting bolts and remove the driving belt.
4. Remove the fan blades and fan pulley.
5. Remove the crankshaft nut, using tool 18G 98 A, and withdraw the crankshaft pulley.
6. Remove the timing gear cover and the crankshaft oil thrower.
7. Unlock and remove the camshaft nut, using tool 18G 98 A.
8. Position the gear wheel timing marks as shown in Fig. 1.
9. Remove the chain tensioner.
10. Draw both chain wheels off their shafts complete with chain.
11. Remove the camshaft locating plate.
 

**If the front plate is not to be removed omit 12, 13, and 15.**
12. Support the engine with an overhead crane or hoist.
13. Remove the bolts retaining the front engine mountings to the body.
14. Remove the bolts retaining the engine mounting brackets to the front plate and crankcase and detach the engine mounting assemblies (Fig. 2).
15. Remove the front plate.
16. Remove the valve rocker cover and the rocker shaft assembly.
17. Withdraw the push-rods. Retain them in their correct order as fitted.
18. Remove the fuel injection pump.
19. Remove the injection pump hub.

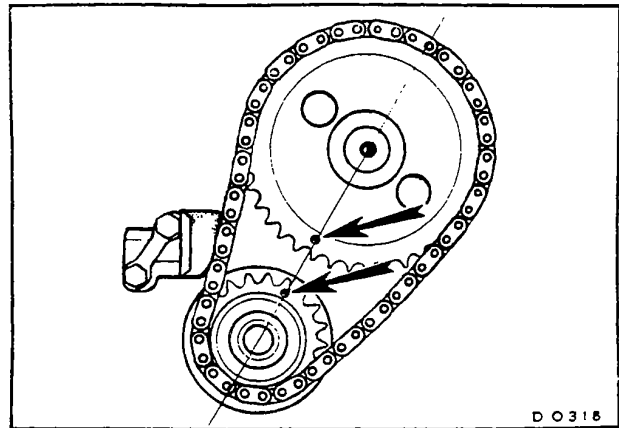

Fig. 1

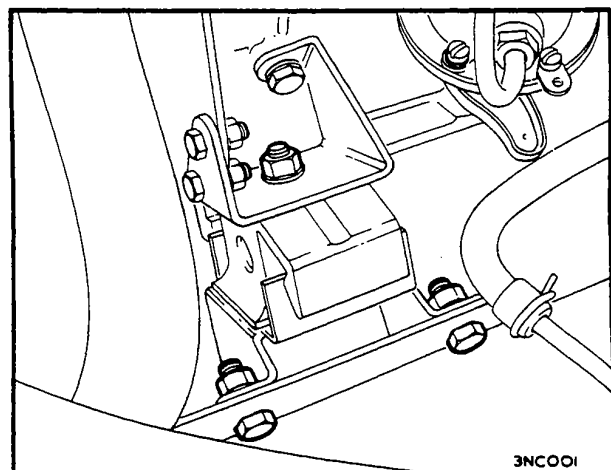

Fig. 2

20. Remove the injection pump driving spindle.
21. Remove the fuel lift pump.
22. Remove the cylinder side covers and lift out the tappets. Retain the tappets in their fitted order.
23. Remove the starter motor.
24. Drain the oil from the sump, and remove the sump.
25. Remove the oil pump and driving spindle.
26. Withdraw the camshaft.

**Refitting**

27. Reverse the procedure in 1 to 26, noting:
  - a. Check the camshaft end float against the figure given in Data.
  - b. Check the chain wheel alignment against the figure given in Data.
  - c. Assemble the chain wheels and chain to the shafts with the timing marks as shown in Fig. 1.
  - d. If necessary, renew the oil seal in the timing gear cover, using tools 18G 134 and 18G 134 BD.
  - e. Centralize the cover with the crankshaft, using tool 18G 1046.
  - f. When the injection pump driving spindle is fully home check that the master spline is in the 5 o'clock position with No. 1 piston at 22° B.T.D.C. on compression stroke.

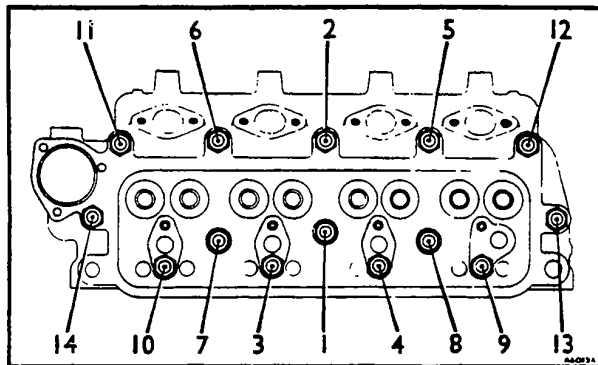

Fig. 3

- g. When refitting the fuel injection pump, position it as described in 'MAINTENANCE'.
- h. Refer to Data for torque wrench settings.
- j. Tighten the cylinder head nuts in the order shown in Fig. 3.
- k. Adjust the valve rocker clearances.
- l. Bleed the fuel system.
- m. Adjust the governed speed (see 'MAINTENANCE').

**Data**

Camshaft end-float .. .. .	0-076 to 0-178 mm (0-003 to 0-007 in)
Crankshaft chain wheel face aligned rearwards of camshaft chain wheel face by .. .. .	0-127 mm (0-005 in)
Method of adjustment .. .. .	Shims behind crankshaft chain wheel
Torque wrench setting for rocker bracket nuts ..	3.5 kgf m (25 lbf ft)



## Section B9

### CONNECTING RODS AND PISTONS

#### Removing

1. Disconnect the battery.
2. Drain the cooling system.
3. Remove the air cleaner and breather hose.
4. Remove the rocker shaft and withdraw the push-rods.
5. Release the leak-off pipe from its union on the fuel filter head.
6. Remove the high pressure fuel feed pipes and the injection pump feed and return pipes.
7. Remove the main fuel filter and its mounting bracket.
8. Disconnect the electrical lead from the heater plugs and the thermal transmitter.
9. Remove the clamp and release the exhaust pipe from the exhaust manifold.
10. Remove the exhaust and inlet manifold from the cylinder head.
11. Disconnect the top water hose from the cylinder head.
12. Remove the cylinder head nuts and lift off the cylinder head.  
**NOTE:** The combustion chamber inserts are a loose fit in the cylinder head. They must be refitted in their original positions because the cylinder head face is machined with the inserts installed.
13. Drain the oil and remove the sump.
14. Remove the oil pump and strainer.
15. Remove the big-end bearing caps.
16. Withdraw the connecting rods and pistons upwards.

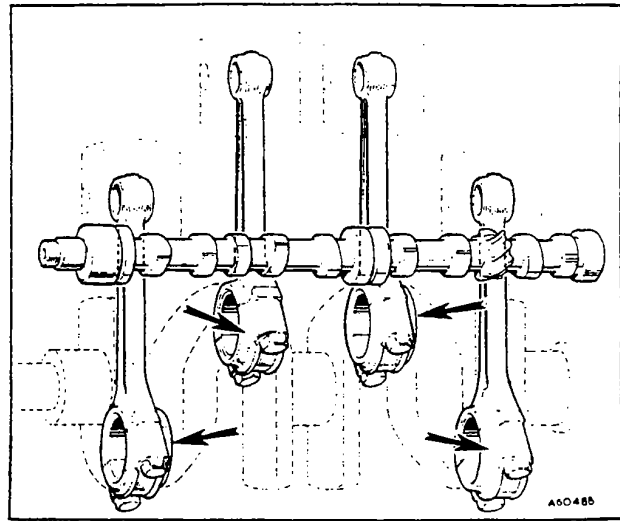

Fig. 1

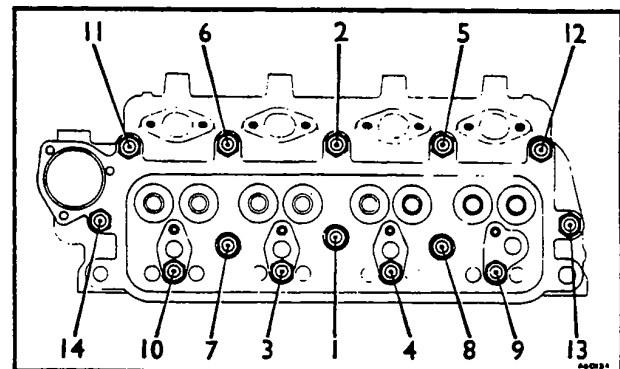

Fig. 2

#### Refitting

17. Reverse the procedure in 1 to 16, noting:
  - a. Refer to Data for torque wrench settings.
  - b. Fit the connecting rods with their offsets as shown in Fig. 1, using tool 18G 55 A to compress the piston rings.
  - c. Tighten the cylinder head nuts in the order shown in Fig. 2, using tool 18G 694.
  - d. Adjust the valve rocker clearance.
  - e. Bleed the fuel system.

#### Data

##### Torque wrench settings:

Big-end bearing cap bolts	..	..	..	..	4.84 kgf m (35 lbf ft)
Cylinder head nuts	..	..	..	..	9.8 kgf m (71 lbf ft)
Manifold nuts	..	..	..	..	2.1 kgf m (15 lbf ft)
Rocker bracket nuts	..	..	..	..	3.4 kgf m (25 lbf ft)

## Section B10

## FLYWHEEL

## Removing

1. Remove the engine.
2. Mark the clutch assembly and the flywheel for re-assembly.
3. Remove the drive assembly.
4. Unlock and remove the flywheel retaining nuts and lock washers.
5. Mark the flywheel and crankshaft flange for reassem-

bly, or set the engine with No. 1 piston at T.D.C. and the flywheel with its mark 1/4 at the top.

6. Remove the flywheel.

## Refitting

7. Reverse the procedure in 1 to 6, noting:
  - a. Bleed the fuel system.

## Data

Torque wrench setting for flywheel bolts    ..    ..    5.1 kgf m (37 lbf ft)

## Section B11

## CRANKSHAFT

## Removing

1. Drain the sump.
2. Remove the engine (see Section 1).
3. Slacken the alternator mounting bolts and remove the driving belt.
4. Remove the fan blades and pulley.
5. Remove the crankshaft nut, using tool 18G 98 A.
6. Withdraw the crankshaft pulley.
7. Remove the timing cover.
8. Remove the oil thrower from the crankshaft.
9. Remove the camshaft nut, using tool 18G 98 A.
10. Remove the chain tensioner, noting that the slipper head is under spring tension.
11. Draw both chain wheels and chain off their shafts.
12. Remove the camshaft locating plate.
13. Remove the front engine plate.
14. Remove the flywheel and starter motor.
15. Remove the flywheel housing.
16. Remove the sump.
17. Remove the oil pump and strainer.
18. Remove the big-end bearing caps.
19. Remove the main bearing caps, using tools 18G 284 and 18G 284 A.
20. Lift out the crankshaft and collect the main bearing and thrust washer halves.

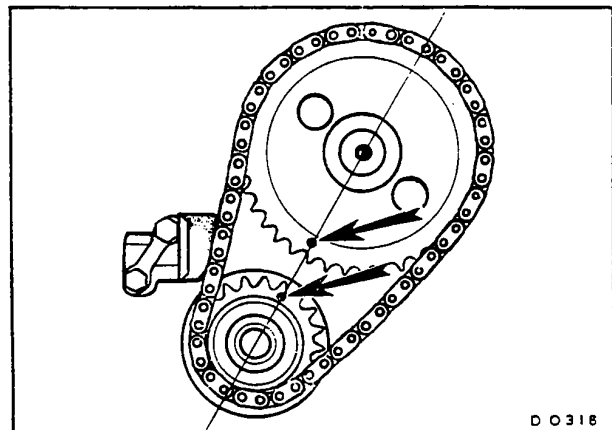

Fig. 1

## Refitting

21. Reverse the procedure in 1 to 20, noting:
  - a. Check the crankshaft end-float against the figure given in Data.
  - b. Refer to Data for torque wrench settings.
  - c. Fit the flywheel so that its 1/4 mark is at the top when Nos. 1 and 4 pistons are at top dead centre.

- d. Check the timing chain wheel alignment. See Data.
- e. Assemble the chain and chain wheels with the timing marks as shown in Fig. 1.
- f. If necessary, renew the timing cover oil seal using tools 18G 134 and 18G 134 BD.
- g. Centralize the timing cover with the crankshaft using tool 18G 1046.
- h. Bleed the fuel system.

### Data

Crankshaft chain wheel face aligned rearwards of camshaft

chain wheel face by	..	..	..	..	..	0.127 mm (0.005 in)
Method of adjustment	..	..	..	..	..	Shims behind crankshaft chain wheel
Torque wrench settings:						
Big-end bolts	..	..	..	..	..	4.84 kgf m (35 lbf ft)
Main bearing nuts	..	..	..	..	..	10.4 kgf m (75 lbf ft)

---

**C**  
**OVERHAULING**

## Section C1

### VALVE ROCKER SHAFT AND TAPPETS

#### Valve rockers

1. Remove the shaft locating screw from the rear rocker bracket.
2. Withdraw the split pins from the shaft ends.
3. Slide the components off the rocker shaft.
4. Unscrew the plug from the front end of the shaft to clean the shaft internally.
5. Renew worn rocker bushes, using tool 18G 226 as shown in Fig. 1.
  - a. Drill the bushes to coincide with the oilways in the rockers.
  - b. Position the bushes in the rockers as shown in Fig. 2.
6. Burnish-ream the bushes to the dimension given in Data.
7. Fit the rear rocker bracket to the shaft and position it with the locating screw.
8. Fit the remaining components to the shaft in the positions shown in Fig. 3.
9. Worn tappet bores may be cleaned up by fine-finish machining to suit oversize tappets (see Data).

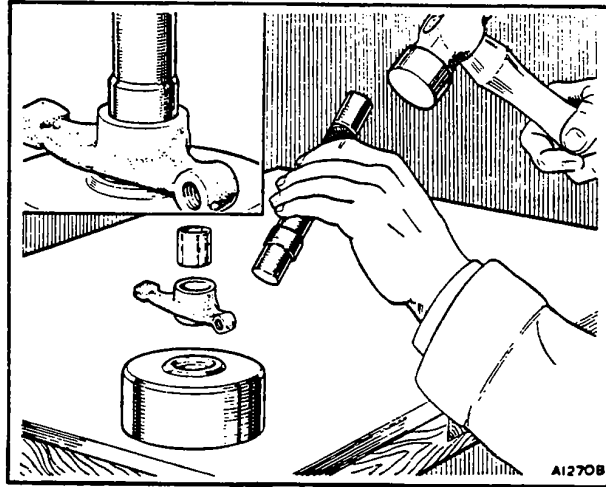

Fig. 1

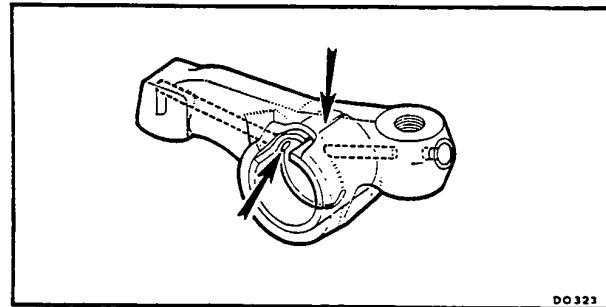

Fig. 2

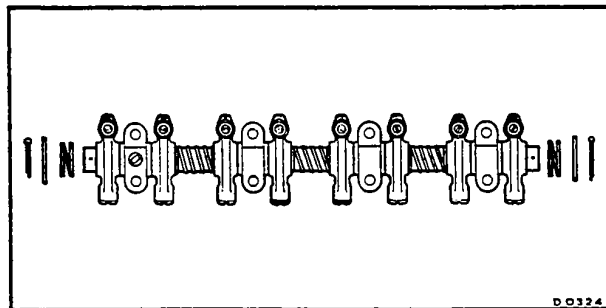

Fig. 3

#### Data

Bush bore reamed diameter	..	..	..	..	15.888 to 15.9 mm (0.6255 to 0.626 in)
Tappet diameter	..	..	..	..	20.65 to 20.618 mm (0.81125 to 0.81175 in)
Tappet oversizes	..	..	..	..	0.254 and 0.508 mm (0.010 and 0.020 in)
Clearance in crankcase	..	..	..	..	0.013 to 0.051 mm (0.0005 to 0.002 in)

Section C2

CYLINDER HEAD

1. Detach the spring clips from the valve cotters.
2. Remove the valves and their components, using tool 18G 45.
3. Renew the valve springs if, when compressed under the same load as a new spring, they show more than  $\frac{1}{8}$  in more compression compared with a new spring.
4. If the valve guides are worn, drive them out through the upper face of the cylinder head. Fit new valve guides through the ports and drive them in to the position shown in Fig. 2.
5. Check the cylinder head face for flatness. Reface the surface if necessary to the dimensions given in Data.
6. If necessary, regrind the valves to the angle given in Data, and reface the valve seats with the tools listed in 'SERVICE TOOLS'.
7. Lap the valves onto their seats, using tool 18G 29.
8. Check the valve head stand-down (see Data). If stand-down is excessive, even with a new valve fitted, machine the cylinder head (see Data) and fit valve seat inserts. Inserts should also be fitted if normal refacing will not restore the seats.
9. Renew the valve stem oil seals, and reassemble the valve components to the cylinder head as shown in Fig. 1.

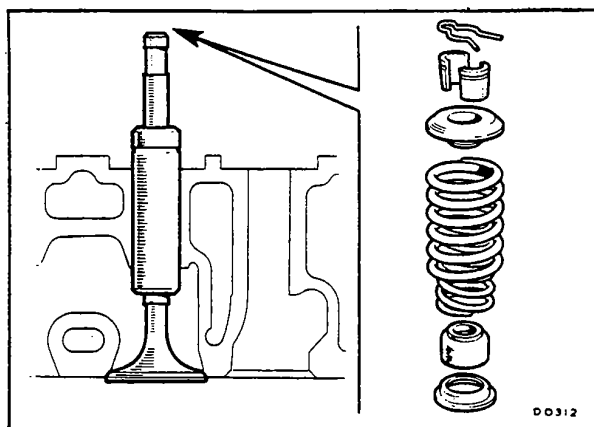

Fig. 1

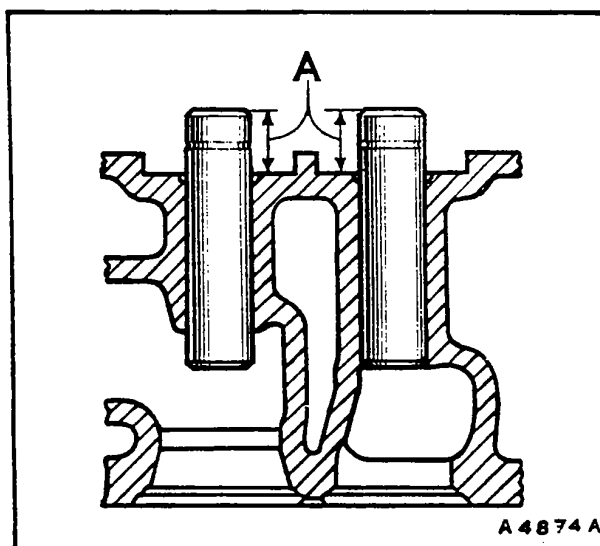

Fig. 2

Data

Cylinder head skimming allowance	.. .. .	0.38 mm (0.015 in) provided the finished cylinder head depth is not less than 80.19 mm (3.157 in)
Valve seating face angle	.. .. .	44 $\frac{1}{2}$ °
Valve head stand-down	.. .. .	0.508 to 0.762 mm (0.020 to 0.030 in)

Section C3

TIMING CHAIN TENSIONER

1. If ovality near the mouth of the tensioner body bore exceeds 0.076 mm (0.003 in) renew the complete chain tensioner.
2. If the slipper head is worn, renew the slipper head and cylinder assembly.

## Section C4

## OIL PRESSURE RELIEF VALVE

1. Unscrew the cap nut shown in Fig. 1 and withdraw the relief valve spring.
2. Remove the valve cup, using tool 18G 69.
3. If the valve cup to seat contact is unsatisfactory, lap the valve cup onto its seat with tool 18G 69.
4. Renew the valve spring if free length is less than 72.64 mm (2.86 in).
5. Reassemble the components to the crankcase.

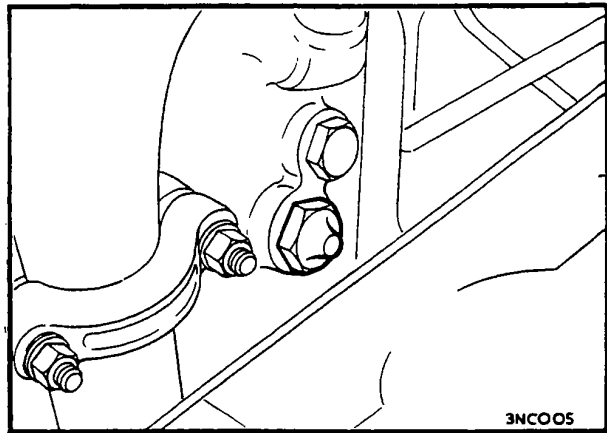

Fig. 1

## Section C5

## INJECTION PUMP DRIVING GEAR LUBRICATOR AND FILTER

1. Unscrew the lubricator from the crankcase and clean it thoroughly.
2. Unscrew the lubricator filter from the crankcase and clean it thoroughly.
3. Refit the filter and lubricator.

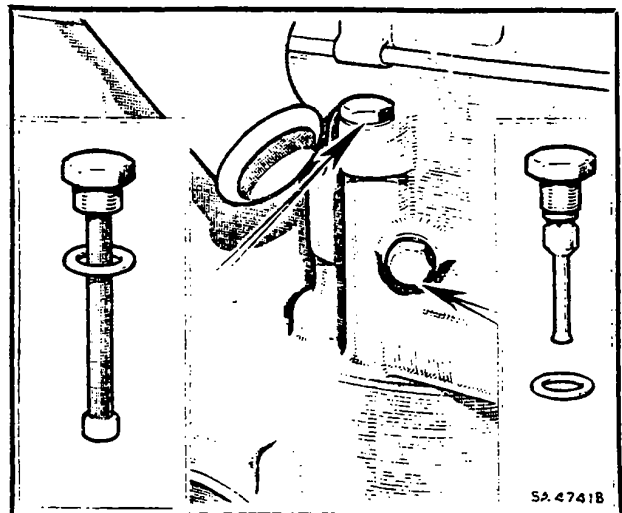

Fig. 1

Section C6

OIL PUMP

1. Remove the pump cover.
2. Check the rotor end-float against the figure in Data. Excessive end-float can be corrected by lapping the pump body face.
3. Check the diametrical clearance between the outer rotor and the pump body against the figure in Data. Renew the rotors, or pump body, or both, as necessary to correct excessive clearance.
4. Check the rotor lobe clearance (in two positions) against the figure in Data. Renew the rotors if clearance is excessive.
5. Reassemble the components, ensuring that the chamfered end of the outer rotor is innermost in the pump body.

Data

Rotor end-float	.. .. .	0.127 mm (0.005 in)
Diametral clearance of outer rotor to pump body	..	0.254 mm (0.010 in)
Rotor lobe clearance	.. .. .	0.152 mm (0.006 in) maximum

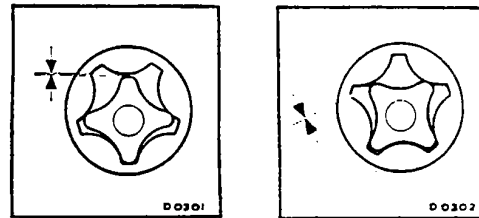

Section C7

CAMSHAFT BEARING LINERS

1. Withdraw the front bearing liner, using the tools shown in Fig. 1.

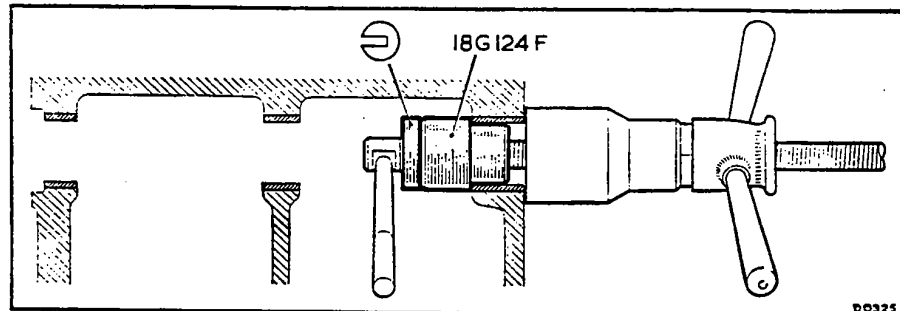

Fig. 1

2. Withdraw the rear bearing liner, using the tools shown in Fig. 2.

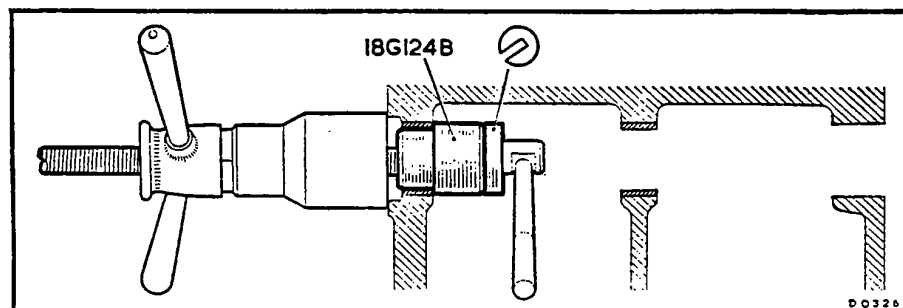

Fig. 2



3. Withdraw the centre bearing liner, using the tools shown in Fig. 3.

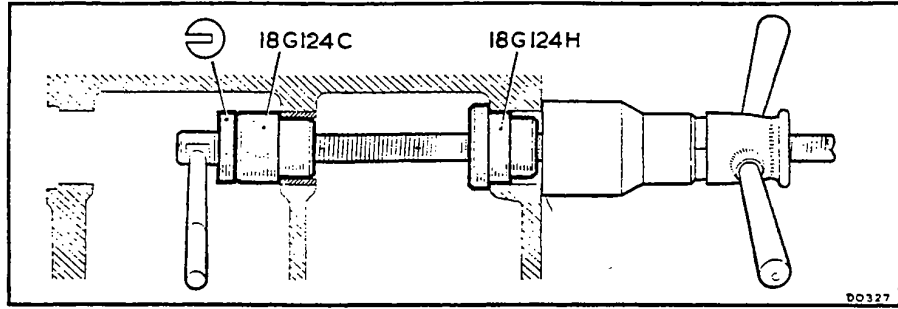

Fig. 3

4. Fit a new front bearing liner, using the tools shown in Fig. 4, and lining up the oil holes in the liner with those in the crankcase.

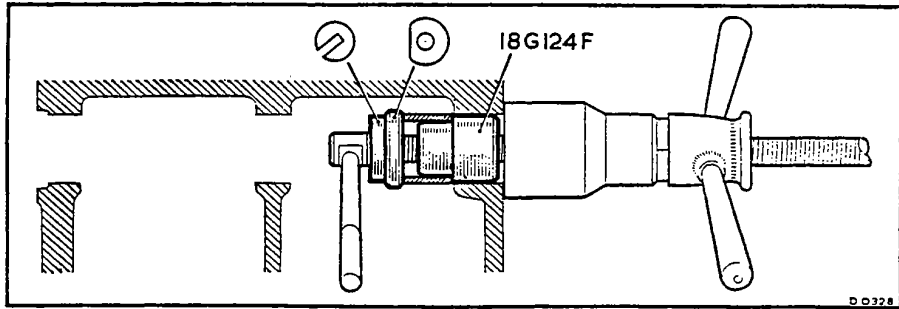

Fig. 4

5. Fit a new rear bearing liner, lining up the oil holes and using the tools shown in Fig. 5.

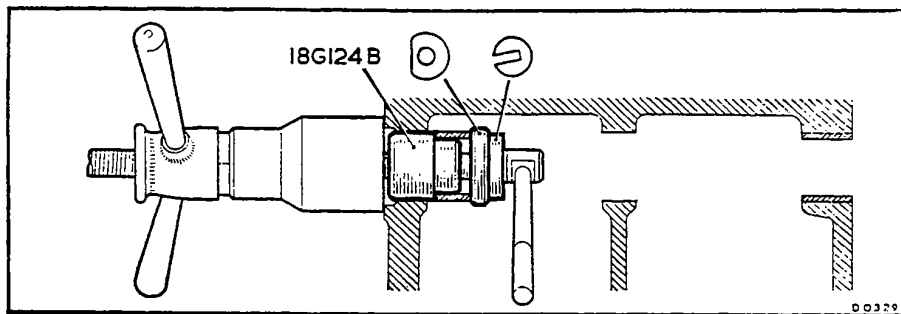

Fig. 5

6. Fit a new centre bearing liner, lining up the oil holes and using the tools shown in Fig. 6.

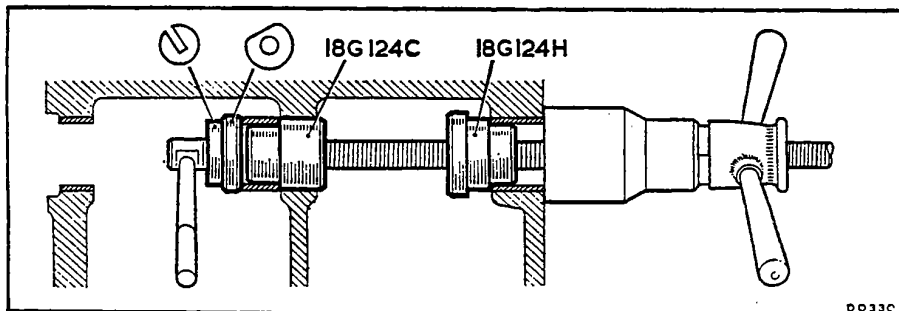

Fig. 6

7. Ream the front and rear bearing liners, using the tools shown in Fig. 7.

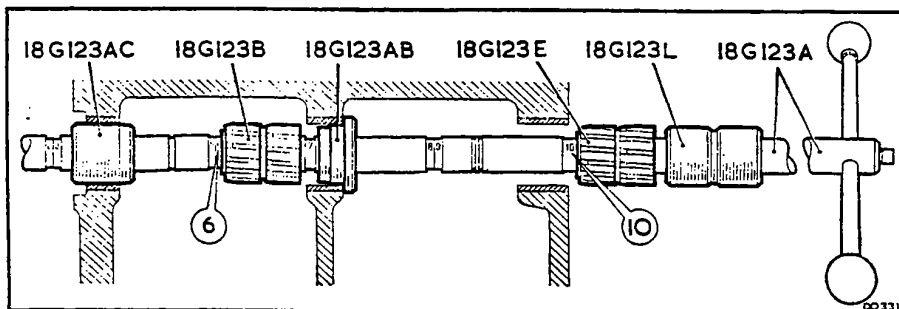

Fig. 7

8. Ream the centre bearing liner, using the tools shown in Fig. 8.

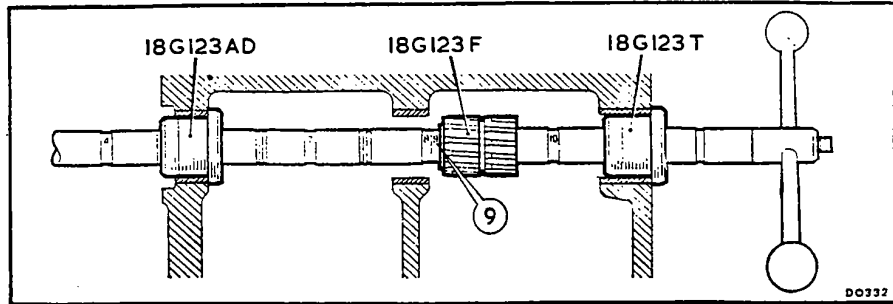

Fig. 8

Section C8

FLYWHEEL

1. If the teeth on the starter ring are worn or damaged, remove the starter ring by drilling a hole and splitting the ring across the hole with a hammer and chisel.
2. Heat the new starter ring uniformly to a temperature between 200 and 230°C (392 and 446°F); the strip of temperature-indicating paint on the ring will change from pink to grey at the correct temperature.
3. Fit the starter ring with the tooth chamfer facing away from the flywheel register.

Section C9

CYLINDER BORES

1. If the cylinder bores cannot be cleaned up at the maximum oversize given in Data, bore them to the dimension given for fitting cylinder liners.
2. Press in the cylinder liners and then bore them to the standard bore size.

Data

Cylinder bore:

Standard	..	..	..	..	..	..	73.01 to 73.02 mm (2.8745 to 2.876 in)
Oversizes: First	..	..	..	..	..	..	0.254 mm (0.010 in)
Second (maximum if lined)	..	..	..	..	..	..	0.508 mm (0.020 in)
Third	..	..	..	..	..	..	0.762 mm (0.030 in)
Fourth (maximum)	..	..	..	..	..	..	1.02 mm (0.040 in)
Bore size for fitting liners	..	..	..	..	..	..	76.62 to 76.63 mm (3.0165 to 3.017 in)

## Section C10

### CONNECTING ROD AND PISTON

1. Separate the piston from the connecting rod.
2. Check the gudgeon pin clearance in the little-end bush against the figure in Data. If the clearance is excessive, renew the little-end bush.
  - a. Position the new bush with its joint on the cap side of the connecting rod as shown in Fig. 1.
  - b. Finish-ream the bush to the size given in Data.
3. Check the piston ring groove clearance and the piston ring gap against the figures in Data. Renew the rings, or piston and rings, as necessary.
4. Assemble the piston to the connecting rod with the combustion cavity and oil jet hole in line as shown in Fig. 2.

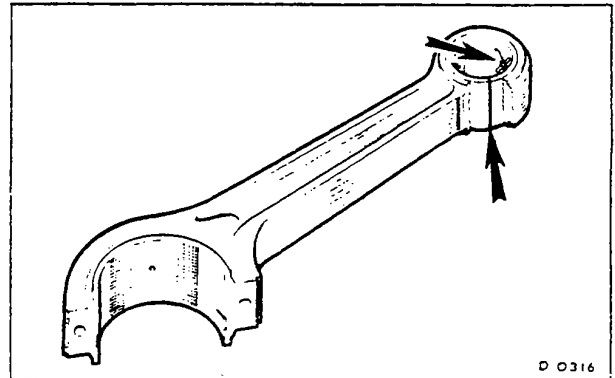

Fig. 1

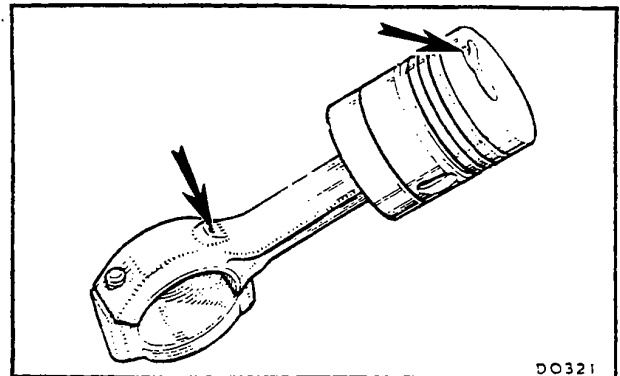

Fig. 2

#### Data

Little-end bush finish reamed diameter .. .. .	25-399 to 25-452 mm (0-9999 to 1-00025 in)
Diameter .. .. .	25-394 to 25-4 mm (0-9998 to 1-0 in)
Fit in piston .. .. .	0-009 mm (0-00035 in) clearance to 0-001 mm (0-00005 in) interference
Fit in connecting rod .. .. .	0-005 to 0-023 mm (0-0002 to 0-0009 in) clearance
Piston to bore clearance at bottom of skirt .. ..	0-091 to 0-106 mm (0-0036 to 0-0042 in)
Ring/groove clearance:	
Top compression .. .. .	0-09 to 0-14 mm (0-0035 to 0-0055 in)
2nd and 3rd compression .. .. .	0-063 to 0-114 mm (0-0025 to 0-0045 in)
Oil control .. .. .	0-051 to 0-102 mm (0-002 to 0-004 in)
Ring gap:	
Top, compression .. .. .	0-305 to 0-432 mm (0-012 to 0-017 in)
Remainder .. .. .	0-203 to 0-330 mm (0-008 to 0-013 in)

## FUEL SYSTEM

<b>B REMOVING AND REFITTING COMPONENTS</b>										<i>Page</i>	<i>Section</i>
Fuel injection pump	..	..	..	..	..	..	..	..	..	B2 .. ..	B3
Injectors	..	..	..	..	..	..	..	..	..	B3 .. ..	B4
Lift pump	..	..	..	..	..	..	..	..	..	B2 .. ..	B1
Main fuel filter	..	..	..	..	..	..	..	..	..	B2 .. ..	B2
 <b>C OVERHAULING</b>											
Injection pump (type DPA 3246857)	..	..	..	..	..	..	..	..	..	C4 .. ..	C1
Injectors	..	..	..	..	..	..	..	..	..	C6 .. ..	C2
Lift pump	..	..	..	..	..	..	..	..	..	C7 .. ..	C3
Main filter	..	..	..	..	..	..	..	..	..	C8 .. ..	C4



**B**

**REMOVING AND REFITTING  
COMPONENTS**

**Section B1****LIFT PUMP****Removing**

1. Disconnect both fuel pipes from the lift pump.
2. Remove the nuts securing the lift pump to the engine and detach the pump.

**Refitting**

3. Reverse the procedure in 1 and 2, noting:
    - a. Renew the gasket between the pump and engine if necessary.
    - b. Bleed the fuel system (see 'MAINTENANCE').
- 

**Section B2****MAIN FUEL FILTER****Removing**

1. Disconnect the fuel pipes from the filter head.
2. Remove the bolts securing the filter to its bracket and detach the filter assembly.

**Refitting**

3. Reverse the procedure in 1 and 2, and bleed the fuel system (see 'MAINTENANCE').
- 

**Section B3****FUEL INJECTION PUMP****Removing**

1. Detach the fuel feed and return pipes from the injection pump and the fuel filter.
2. Detach the high pressure pipes from the pump and the injectors.
3. Disconnect the stop and throttle control cables at their trunnions on the pump levers.
4. Remove the nuts retaining the cable stop bracket to the pump and detach the bracket complete with cables.
5. Remove the nuts and washers retaining the pump to the engine and withdraw the pump from the engine.

**Refitting**

6. Reverse the procedure in 1 to 5, noting:
    - a. Position the crankshaft and set the injection timing pointer as described in 'MAINTENANCE'.
    - b. Fit the injection pump so that the mark on its mounting flange lines up with the timing pointer.
    - c. Bleed the fuel system (see 'MAINTENANCE').
    - d. Adjust the maximum and idling speeds to the figures given in 'GENERAL DATA'.
-

## Section B4

## INJECTORS

**Removing**

1. Disconnect the spill pipes and the high-pressure pipes from the injectors.
2. Remove the injector securing nuts and withdraw the injectors using tool 18G 491 A.

**Refitting**

3. Renew the atomizer sealing washers, fitting new washers as shown in Fig. 1.
4. Reverse the procedure in 1 and 2, and bleed the high pressure pipes.

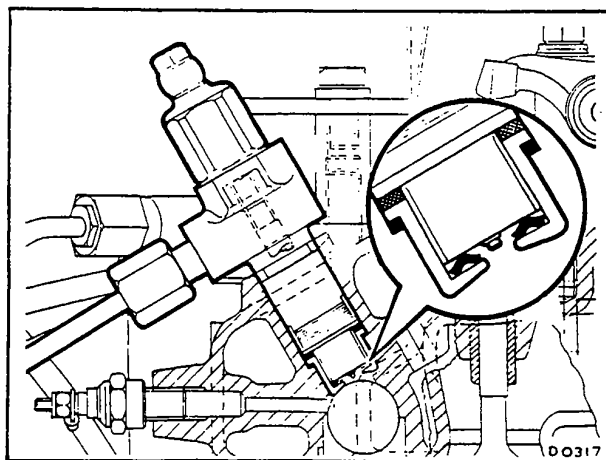

Fig. 1





**C**  
**OVERHAULING**

FUEL INJECTION PUMP COMPONENTS

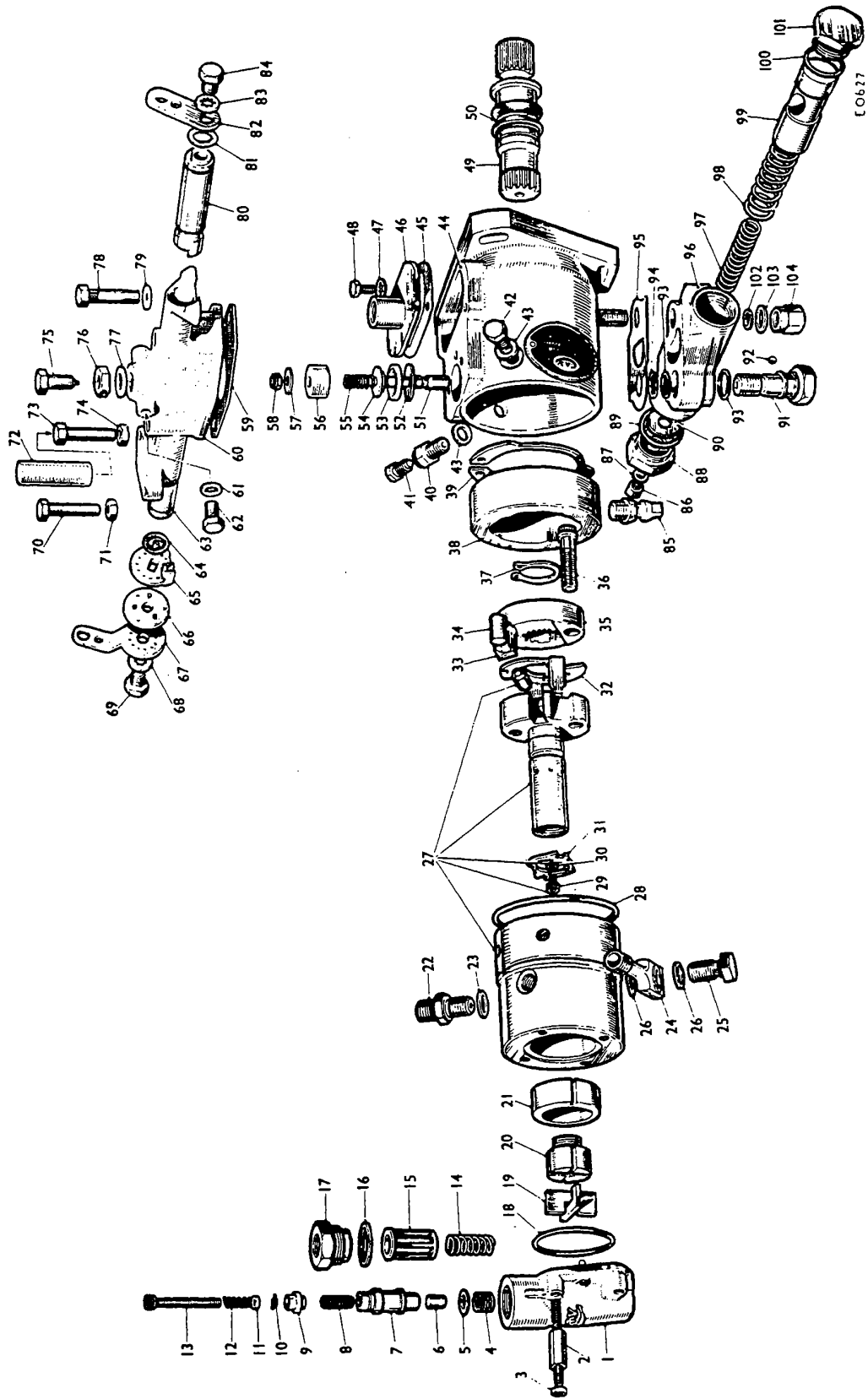

KEY TO FUEL INJECTION PUMP COMPONENTS

- |                                       |   |                                   |
|---------------------------------------|---|-----------------------------------|
| 1. End plate                          | 36. Screw for drive plate                 | 71. Locknut                       |
| 2. Stud for end plate                 | 37. Circlip for drive shaft               | 72. Locking sleeve                |
| 3. Nut for stud                       | 38. Cam ring                              | 73. Maximum speed stop screw      |
| 4. Piston retaining spring            | 39. Circlip for cam ring                  | 74. Locknut                       |
| 5. Washer for sleeve                  | 40. Hydraulic head locking screw (vented) | 75. Idling damper                 |
| 6. Regulating piston                  | 41. Vent screw                            | 76. Locknut                       |
| 7. Regulating sleeve                  | 42. Hydraulic head locking screw (plain)  | 77. Sealing washer                |
| 8. Regulating spring                  | 43. Washer for locking screw              | 78. Screw for governor housing    |
| 9. Plug for sleeve                    | 44. Pump housing                          | 79. Washer for screw              |
| 10. Torsion spring for plug           | 45. Gasket for cover                      | 80. Shut-off shaft                |
| 11. Washer for plug                   | 46. Adjusting hole cover                  | 81. Seal for shaft                |
| 12. Spring for adjusting screw        | 47. Washer for screw                      | 82. Shut-off lever                |
| 13. Adjusting screw                   | 48. Screw for cover                       | 83. Washer for screw              |
| 14. Sleeve retaining spring           | 49. Drive shaft                           | 84. Screw for shut-off lever      |
| 15. Filter                            | 50. Seal for drive shaft                  | 85. Cam advance screw             |
| 16. Washer for inlet connection       | 51. Metering valve                        | 86. Screw for spring cap          |
| 17. Fuel inlet connection             | 52. Damping valve seating washer          | 87. Washer for screw              |
| 18. Seal for transfer pump            | 53. Damping valve centre washer           | 88. Spring cap                    |
| 19. Transfer pump vanes               | 54. Damping valve spring plate            | 89. Seal for cap                  |
| 20. Transfer pump rotor               | 55. Governor spring                       | 90. Shim washer                   |
| 21. Transfer pump liner               | 56. Control sleeve                        | 91. Hydraulic head locating bolt  |
| 22. Radial connection                 | 57. Shut-off washer                       | 92. Non-return valve ball         |
| 23. Washer for connection             | 58. Nut for metering valve                | 93. Seal for locating bolt        |
| 24. Banjo connection                  | 59. Gasket for governor housing           | 94. Washer for locating bolt      |
| 25. Bolt for banjo connection         | 60. Governor housing                      | 95. Gasket for housing            |
| 26. Washer for banjo bolt             | 61. Washer for screw                      | 96. Advance housing               |
| 27. Hydraulic head and rotor assembly | 62. Vent screw                            | 97. Inner spring for piston       |
| 28. Seal for hydraulic head           | 63. Throttle shaft                        | 98. Outer spring for piston       |
| 29. End plug for rotor                | 64. Seal for shaft                        | 99. Advance piston                |
| 30. Washer for plug                   | 65. Stop plate                            | 100. Seal for end plug            |
| 31. Bottom adjusting plate            | 66. Vernier plate                         | 101. End plug                     |
| 32. Top adjusting plate               | 67. Throttle lever                        | 102. Seal for cap nut             |
| 33. Shoe for roller                   | 68. Washer for screw                      | 103. Aluminium washer for cap nut |
| 34. Roller                            | 69. Screw for throttle lever              | 104. Cap nut                      |
| 35. Drive plate                       | 70. Idling stop screw                     |                                   |

## Section C1

## INJECTION PUMP (Type DPA.3246857)

Immerse components in clean calibration fluid as they are removed.

1. Mount the pump on assembly base 18G 633 A.
2. Remove the high-pressure connections.
3. Remove the adjusting hole cover.
4. Remove the governor housing and withdraw the securing screws.
5. Withdraw the throttle and shut-off shafts.
6. Withdraw the metering valve assembly.
7. Dismantle the metering valve assembly, using tool 18G 637.
8. Remove the advance unit, noting the non-return valve ball in the side of the hydraulic head locating bolt.
9. Remove the spring cap (note the adjusting shims), springs, piston, and end plug from the advance housing.
10. Remove the cam ring advance screw, using tool 18G 646.
11. Remove the end plate from the hydraulic head.
12. Withdraw the transfer pump vanes and liner.
13. Remove the fuel inlet connection from the end plate and withdraw the regulating valve components.
14. Slacken the transfer pump rotor (see the 'OFF' direction on the rotor face), using tools 18G 634 and 18G 651.
15. Remove both locking screws and withdraw the hydraulic head assembly.
16. Unscrew the transfer pump rotor.
17. Remove the drive plate and top adjusting plate, using tool 18G 641.
18. Remove the rollers and shoes.
19. Withdraw the rotor and remove the bottom adjusting plate.
20. Withdraw the cam ring.
21. Withdraw the cam ring circlip, using tool 18G 1004.
22. Remove the drive shaft circlip, using tool 18G 1004.
23. Withdraw the drive shaft from the pilot tube.
24. Renew all 'O' rings, oil seals, and gaskets.
25. Renew any springs which are damaged or of incorrect length when compared with new counterparts.
26. Examine the hydraulic head, rotor, pumping plungers, and metering valve. If any of these components are worn or damaged, renew the hydraulic head and rotor assembly.
27. Renew the cam ring and plunger rollers if they show signs of wear or flats.
28. Renew the regulating valve sleeve and piston if they are worn or if the piston is tight in the sleeve.
29. Renew the pump body if the pilot tube bore is scored or worn.
30. Fit the drive shaft oil seals, using tool 18G 635.
31. Fit the drive shaft, using tool 18G 642 A.
32. Fit the drive shaft circlip, using tool 18G 1004.
33. Fit the cam ring circlip, using tool 18G 1004.

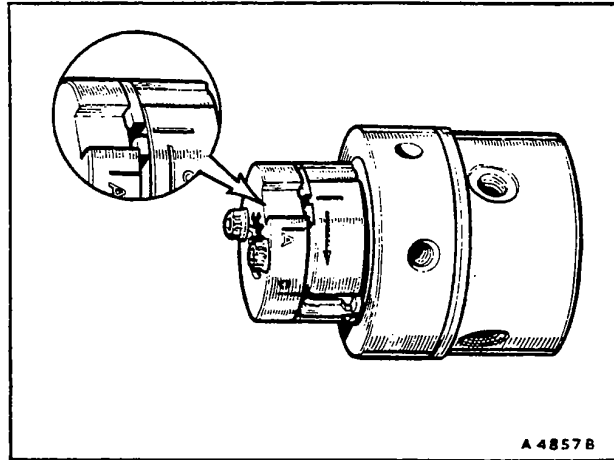

Fig. 1

34. Fit the cam ring (the directional arrow on its visible face should match that on the pump nameplate).
35. Fit the cam advance screw.
36. Fit the top adjusting plate and drive plate as shown in Fig. 1.
37. Fit the roller shoe assemblies.
38. Fit the bottom adjusting plate and insert the rotor into the hydraulic head.
39. Fit the transfer pump rotor.
40. Set the roller-to-roller dimension at the figure given in Data, using tools 18G 653 A (preset at 15 atmospheres) and 18G 109 A as shown in Fig. 2.
41. Tighten the drive plate screws to the torque figure given in Data, using tool 18G 641.

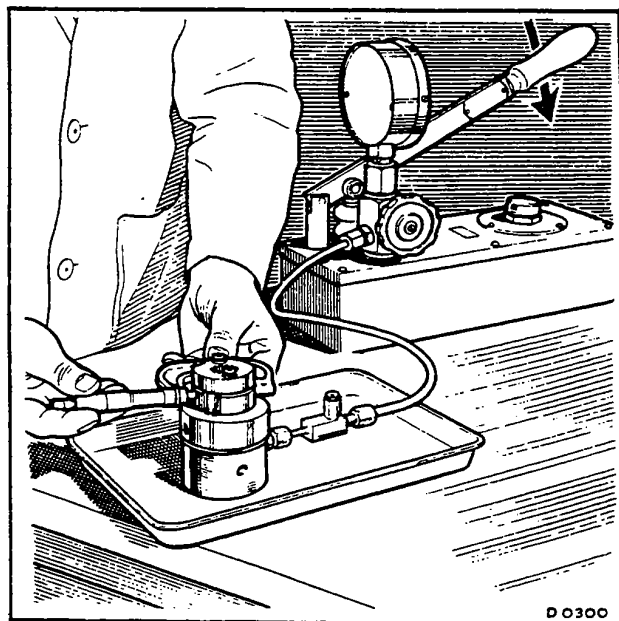

Fig. 2

42. Fit the 'O' ring to the hydraulic head periphery and fit the hydraulic head to the pump body.
43. Fit both hydraulic head locking screws finger tight.
44. Tighten the transfer pump rotor to the torque figure given in Data, using tools 18G 634 and 18G 651.
45. Fit the transfer pump liner and vanes.
46. Assemble the regulating valve components to the end plate in the order shown in Fig. 3.
47. Ensure that the transfer pump liner locating pin is fitted to position 'C' in the end plate.
48. Locate the oil sealing ring on the hydraulic head face, and fit the end plate.
49. Tighten the end plate screws and fuel inlet connection to the torque figures given in Data.
50. Tighten the cam ring advance screw to the torque figure given in Data.
51. Fit 'O' rings to the advance unit end plug and spring cap, using tool 18G 640.
52. Fit the end plug to the advance unit at the end where the fuel drilling enters the bore.
53. Insert the advance piston into its housing, then insert the springs into the piston.
54. Fit the original thickness of shims into the spring cap and fit the cap to the advance unit.
55. Fit the 'O' ring to the hydraulic head locating bolt, using tool 18G 639. Position the non-return valve ball on its seat in the side of the bolt and fit the bolt to the advance unit. Fit the 'O' ring to the shank of the head locating bolt using tool 18G 647 and fit the plain washer on top of the 'O' ring.
56. Fit the advance unit and gasket.
57. Assemble the metering valve components as shown in Fig. 4, using tool 18G 637 when tightening the nut.
58. Fit the 'O' rings to the throttle and shut-off shafts, using tools 18G 643 A and 18G 647.
59. Insert the metering valve into the governor housing and fit the throttle shaft with its end engaging between the shut-off washer and control sleeve.
60. Fit the shut-off shaft.
61. Use tool 18G 691 A to align the metering valve bore with the damping valve bore, and tighten both hydraulic head locking screws to the torque figure given in Data.
62. Tighten the advance unit cap nut, hydraulic head locating bolt, end plug, and spring cap to the torque figures given in Data.
63. Fit the governor housing and joint washer. The throttle lever should be on the nameplate side of the pump housing.
64. Fit the adjusting hole cover.
65. Mount the pump on a test bench.
66. Fit radial connections to the high-pressure outlets.
67. Remove the plain hydraulic head locking screw and fit adaptor 18G 636.
68. Fit end plate adjuster 18G 690 to the inlet connection. Unscrew the adjuster fully then screw it in 1½ turns.

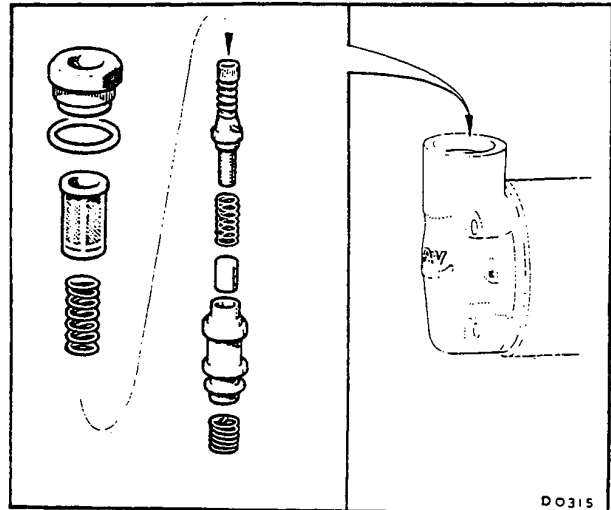

Fig. 3

69. Remove the screw from the advance unit spring cap and fit advance gauge 18G 638 B. Zero the gauge.
70. Set the stop screws to give maximum throttle lever movement.
71. Make the following pump to test bench connections:
  - a. Radial connections to injectors.
  - b. Hydraulic head adaptor to pressure gauge.
  - c. End plate adjuster to feed pipe (with a branch off to vacuum gauge).
  - d. Adjusting hole cover, via measuring glass, to drain pipe.
72. Prime the injection pump as follows:
  - a. Turn on the fuel feed.
  - b. Slacken the feed pipe at the injection pump until the fuel is flowing from it free of air bubbles.
  - c. Air vent the pump from the hydraulic head vent screw.
  - d. Rotate the pump drive through 90° and again vent the hydraulic head.
  - e. Air vent the pump from the vent valve on the governor housing.

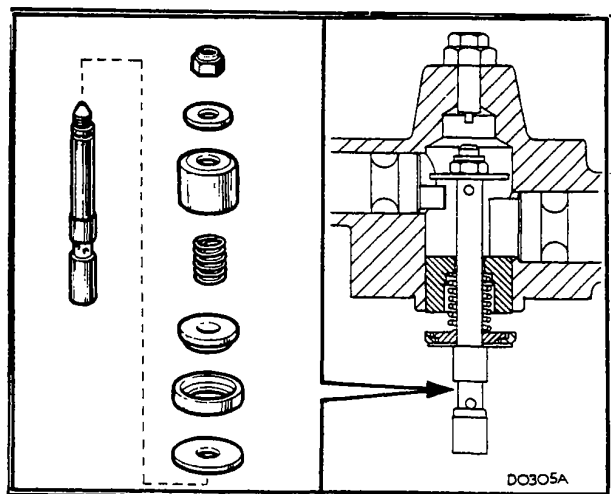

Fig. 4

- f. Ensure that the pump body is filled with fuel by removing and refitting the adjusting hole cover.
- g. Run the pump at 100 rev/min (see pump name-plate for rotation) and bleed the high-pressure

pipes until delivery is obtained from all injectors.  
 73. Test and adjust the pump in accordance with the manufacturer's instructions.

### Data

Roller to roller dimension .. .. .	50.22 mm (1.977 in)
Torque wrench settings:	
Drive plate screws:	
Direct torque .. .. .	1.85 kgf m (160 lbf in)
Indirect torque (using tool 18G 655A) .. .. .	1.62 kgf m (140 lbf in)
Transfer pump rotor .. .. .	0.75 kgf m (65 lbf in)
Cam ring advance screw .. .. .	5.16 kgf m (450 lbf in)
End plate screws .. .. .	0.52 kgf m (45 lbf in)
Fuel inlet connection .. .. .	5.16 kgf m (450 lbf in)
Hydraulic head locking screws .. .. .	1.96 kgf m (176 lbf in)
Advance unit cap nut .. .. .	1.5 kgf m (130 lbf in)
Hydraulic head locking bolt .. .. .	4.03 kgf m (350 lbf in)

## Section C2

### INJECTORS

1. Mount the injector in dismantling fixture 18G 388.
2. Remove the injector cap nut, spring cap nut, spring, and spindle.
3. Remove the nozzle nut and nozzle, using tool 18G 210.
4. Renew the spring if it shows any signs of weakness.
5. Renew the spindle if it is not perfectly straight.
6. Clean the nozzle and valve, using kit 18G 487, and reverse-flush the nozzle with tools 18G 109 A and 18G 109 E.
7. Renew the nozzle assembly if the pintle clearance is excessive when checked as shown in Fig. 1.
8. If necessary, restore the nozzle and valve seats to the angles given in Data.
9. Check the needle lift against the figure in Data.
10. Mount the nozzle holder in the dismantling fixture and reverse the procedure in 2 and 3, tightening the nozzle nut to the torque figure given in Data.
11. Test and adjust the injector to the manufacturer's specification.

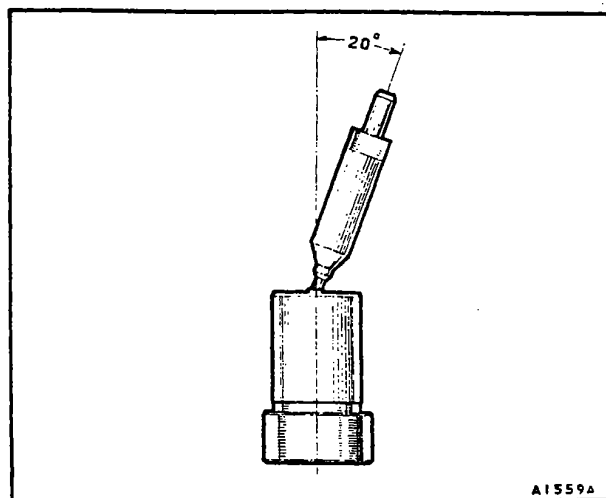

Fig. 1

### Data

Nozzle seat angle .. .. .	59°
Valve seat angle .. .. .	60°
Needle lift .. .. .	0.6 to 0.75 mm (0.236 to 0.295 in)
Nozzle nut torque wrench setting .. .. .	6.91 kgf m (600 lbf in)

Section C3

LIFT PUMP

1. Scribe a reassembly mark across the body joint flanges.
2. Remove the screw retaining the domed cover and detach the cover, gasket and filter gauze.
3. Remove the securing screws and separate the top and bottom halves of the pump body.
4. Press the diaphragm lightly downwards, rotate it through 90 degrees, and withdraw the diaphragm, spring and oil seal.
5. Check the rocker arm pin and linkage for wear or damage. If necessary, secure the rocker arm in a vice and tap the face of the pump mounting flange to dislodge the rocker arm pin retainers. Renew the components as necessary, then reassemble the rocker arm, operating link and spacing washers onto the rocker arm pin. Place this assembly and the rocker arm return spring, in position in the pump body and tap two new rocker arm pin retainers fully home in their grooves. Secure the retainers by staking the ends of the grooves.
6. If the valves need renewing, lever them out carefully with a screwdriver. Renew the valve gaskets, press in the new valves and stake them in position.
7. Renew the diaphragm if necessary.
8. If a new diaphragm spring is fitted, ensure that it has the same identification colour as the original spring.
9. Renew the diaphragm rod oil seal, and the seals for the domed cover and its securing screw.
10. Reverse the procedure in 1 to 4.

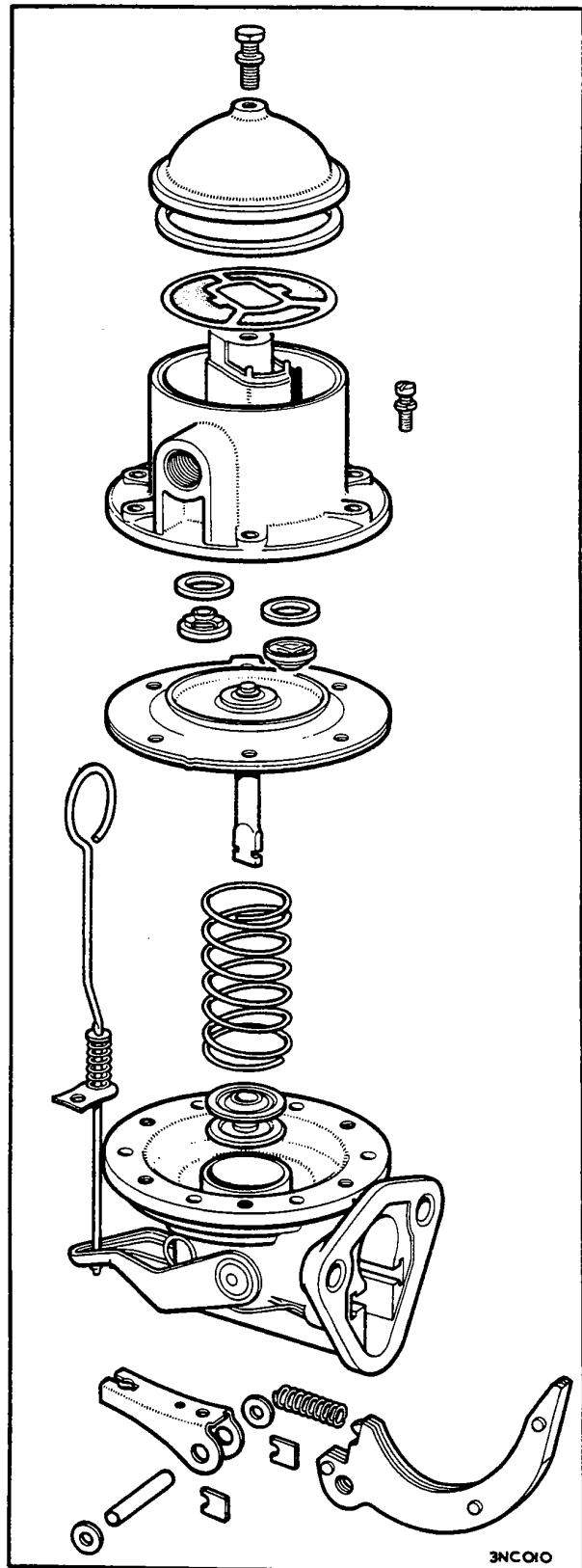

Fig. 1



## Section C4

## MAIN FILTER

1. Unscrew the centre bolt and remove the filter base and element.
2. Check the operation of the non-return valve in No. 4 connection.
3. Renew the filter element, and the 'O' ring and sealing rings in the filter head and base.
4. Reassemble the filter components as shown in Fig. 1.

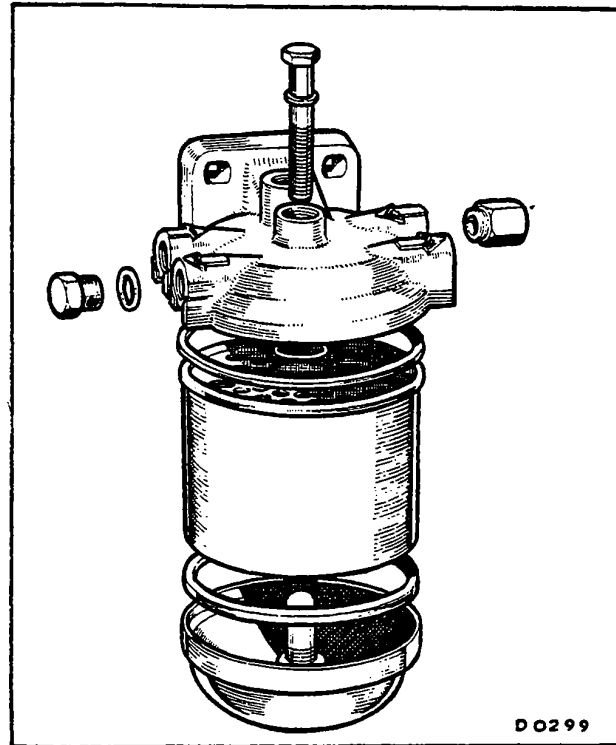

Fig. 1

**COOLING SYSTEM**

**C OVERHAULING**

	<i>Page</i>	<i>Section</i>
Water pump .. .. .	53/C2	C1



**C**  
**OVERHAULING**

## Section C1

## WATER PUMP

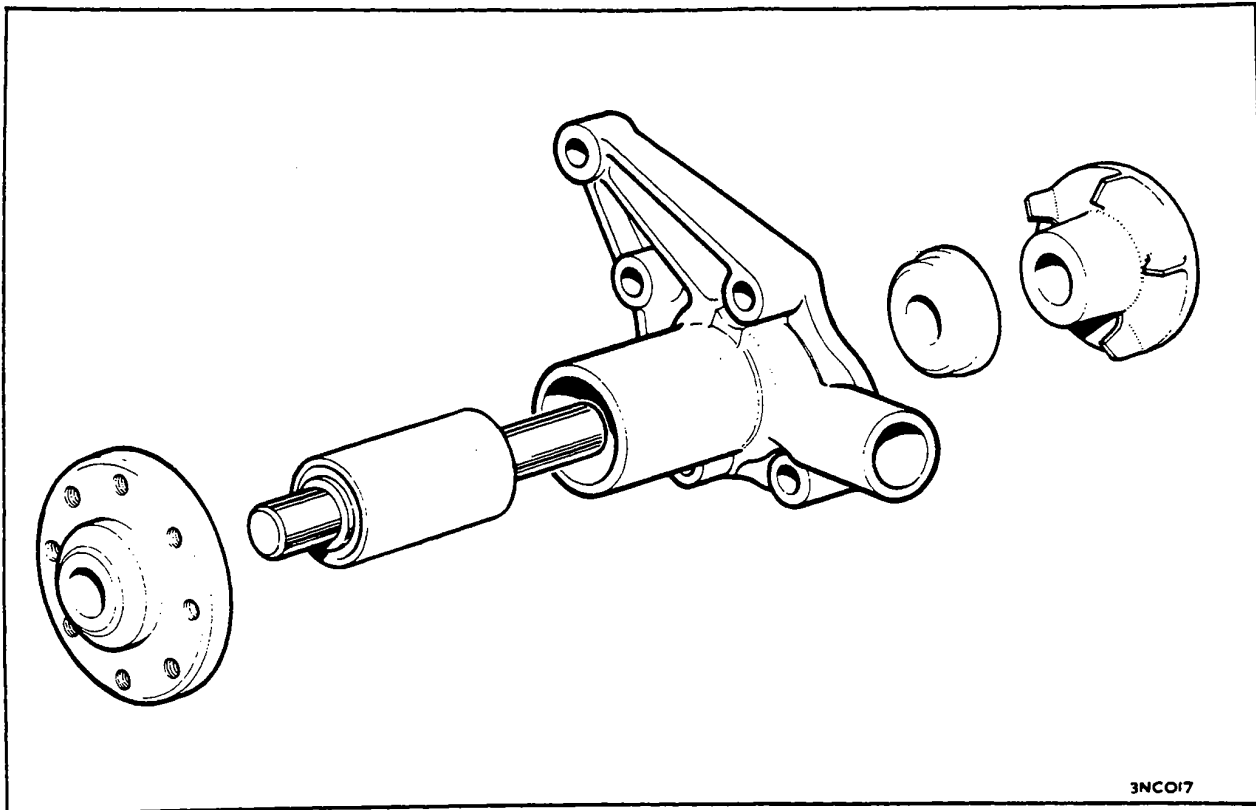

Fig. 1

1. Press the bearing spindle out of the pulley hub.
2. Support the pump body and press the bearing assembly out of the body complete with water seal and impeller.
3. Press the bearing spindle out of the impeller.
4. Remove the water seal from the spindle.
5. Examine the components for wear or damage, and renew if necessary. If the interference fit on the bearing spindle of either the pulley hub or impeller has been impaired the hub and/or impeller must be renewed.

6. Press the bearing assembly into the body to the dimension given in Data.
7. Support the bearing spindle and press the pulley hub onto the spindle to the dimension given in Data.
8. Refit the water seal, support the bearing spindle, and press the impeller onto the spindle to the dimension given in Data.

**Data****Assembly dimensions**

- A = 13.39 to 13.64 mm (0.527 to 0.537 in)  
 B = 0.508 to 0.762 mm (0.020 to 0.030 in)  
 C = 94.74 to 95.25 mm (3.730 to 3.750 in)

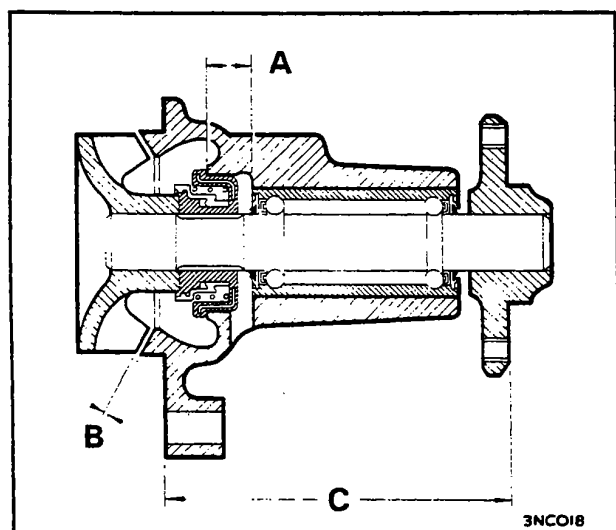
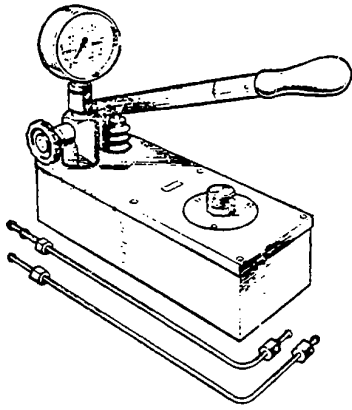

Fig. 2

**SERVICE TOOLS**



3899A

18G 109 A. Injector Nozzle Testing Machine

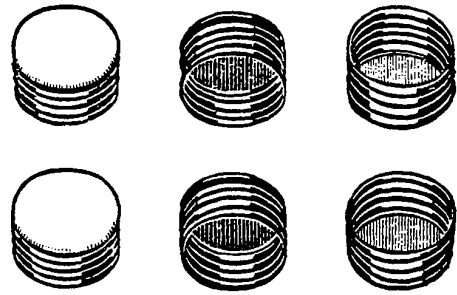

AD1248

18G 216. F.I. Pump Outlet Sealing Caps

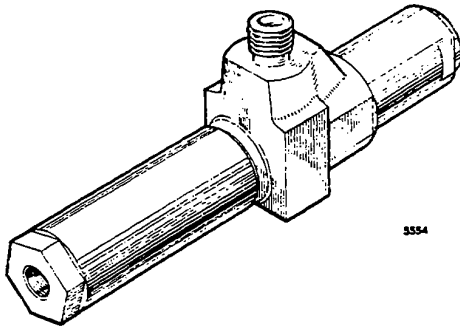

3554

18G 109 B. Pintaux Nozzle Testing Adaptor

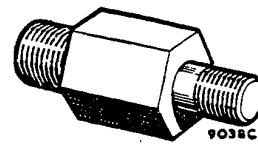

9036C

18G 284 A. Main Bearing Cap Remover Adaptor

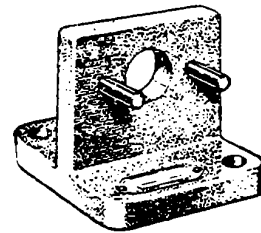

4362D

18G 388. Injector Dismantling Fixture

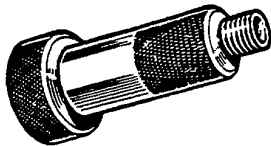

9131

18G 109 E. Injector Nozzle Reverse Flush Adaptor

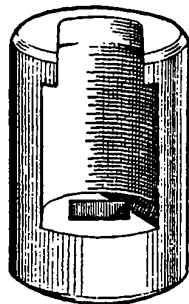

9137

18G 210. Injector Nozzle Nut Spanner

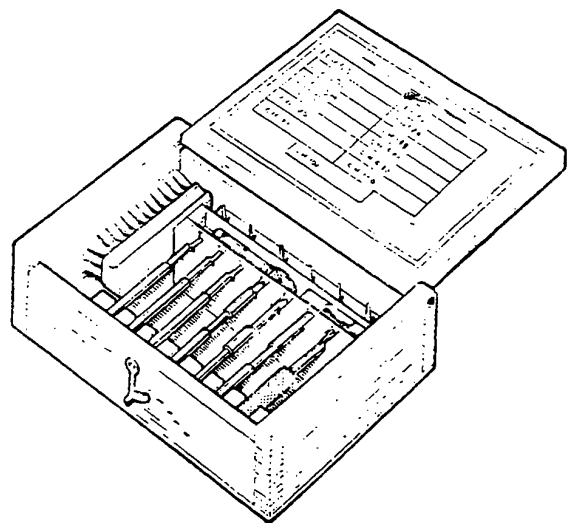

4470F

18G 487. Injector Nozzle Cleaning Kit

## SERVICE TOOLS

---

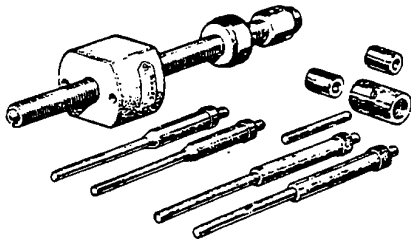

4462K

**18G 491 A. Injector Remover**

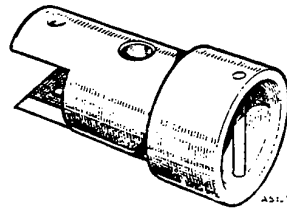

AS1-2

**18G 634. Assembly Box Spanner**

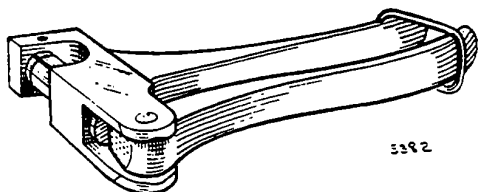

5392

**18G 541. Venturi and F.I. Pump Sealing Pliers**

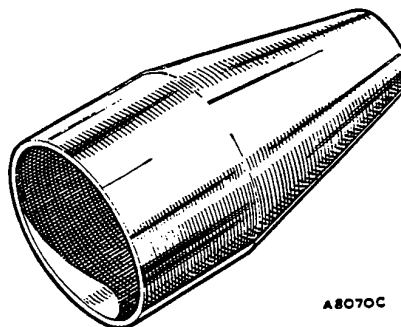

A8070C

**18G 635. Hydraulic Drive Shaft Protection Cap**

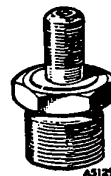

AS129

**18G 636. Transfer Pressure Adaptor**

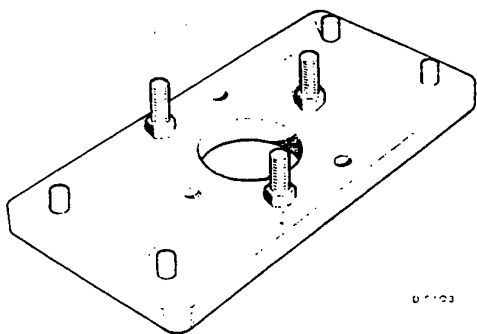

07103

**18G 633 A. D.P.A. Assembly Base**

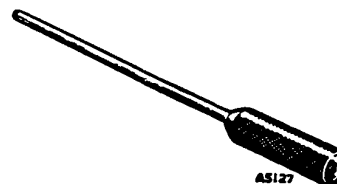

AS127

**18G 637. Assembly Rod**



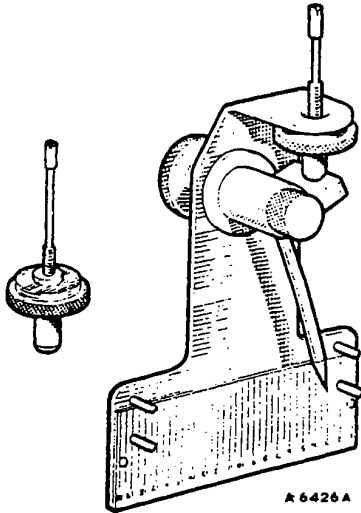

**18G 638 B. Automatic Advance Gauge**

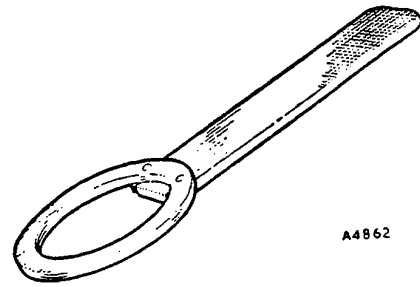

**18G 641. Assembly Drive Plate Spanner**

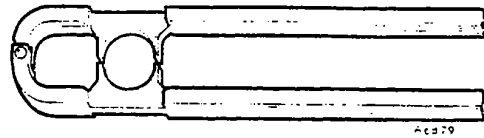

**18G 642 A. Hydraulic Shaft Seal Assembly Tool**

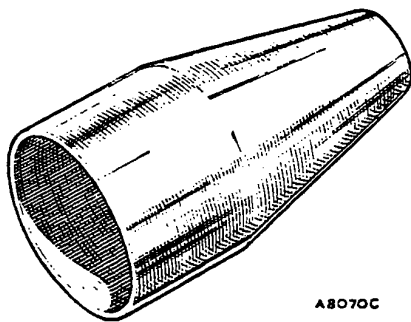

**18G 639. Protection Cap for Head Locating Fitting**

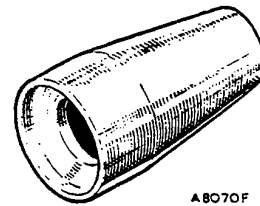

**18G 643 A. Protection Cap for Metering Valve Pinion**

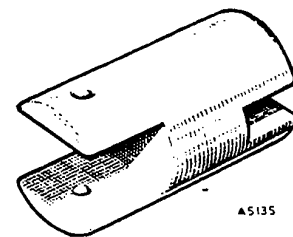

**18G 646. Torque Spanner Socket**

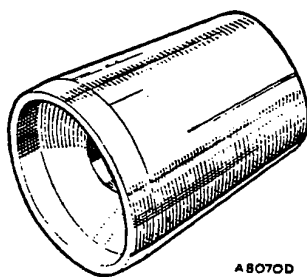

**18G 640. Protection Cap for Automatic Advance Plug**

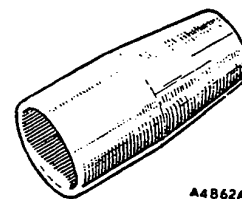

**18G 647. Assembly Cap**

# SERVICE TOOLS

---

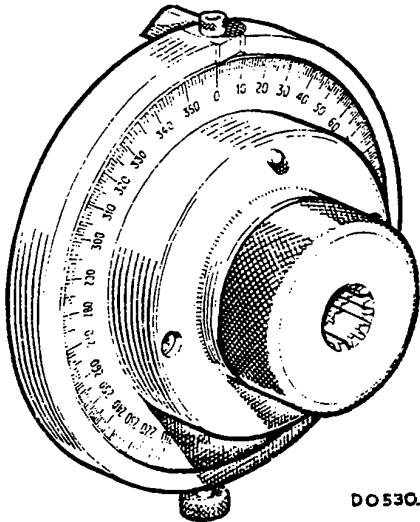

DO530.

**18G 648 A. Universal Flange Marking Gauge**

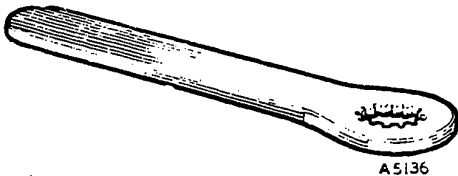

A5136

**18G 651. Drive Shaft Holding Tool**

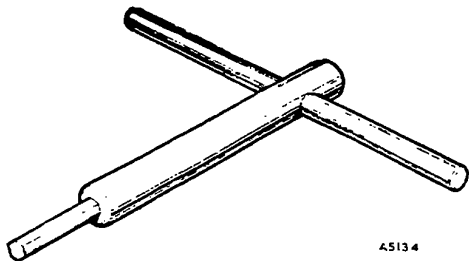

A5134

**18G 652. Rotor Plug Spanner**

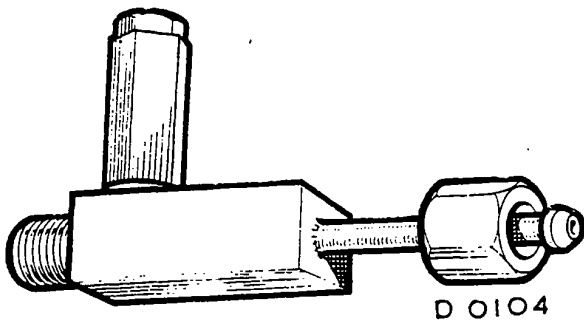

D 0104

**18G 653 A. Relief Valve Timing Adaptor**



A 6878

**18G 655 A. Drive Plate Screw Torque Adaptor**

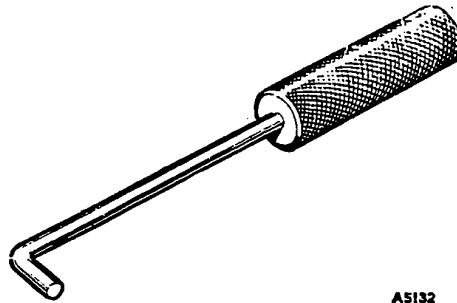

A5132

**18G 656. Maximum Fuel Adjusting Probe**

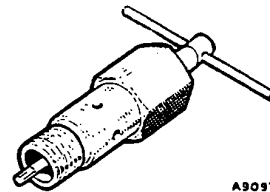

A9097

**18G 690. End Plate Adjuster**

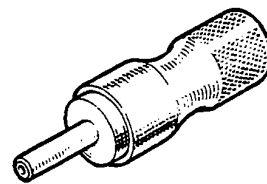

A9098A

**18G 691 A. Pilot Guide**

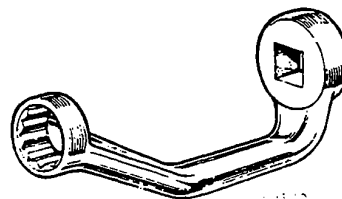

**18G 694. Cylinder Head Nut Spanner**

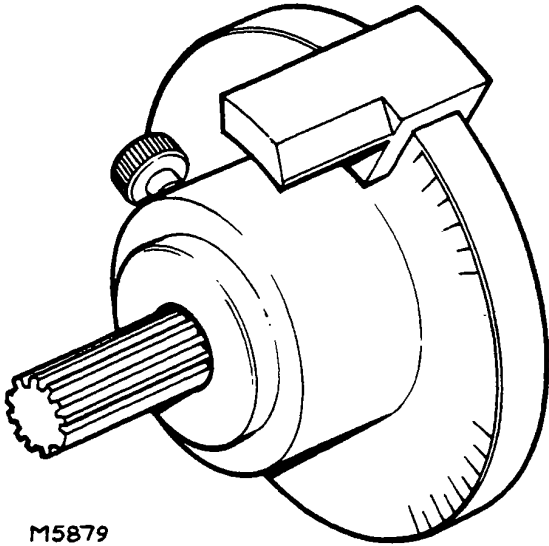

M5879

**MS67A Universal Timing Gauge**

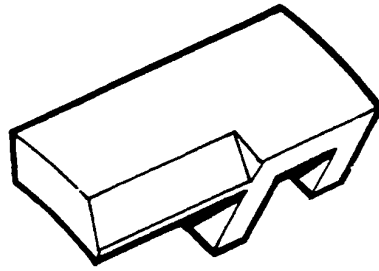

M5881

**MS67A/2B Universal Timing Gauge Scribing Arm**